



## **Anhydrous Ammonia Emergency Responder**

### **Participant Guide**

Copyright © 2023  
Midwest Consortium for Hazardous Waste Worker Training

## Acknowledgments

The Midwest Consortium developed this course for emergency responders under cooperative agreement number U45 ES 06184 from the National Institute of Environmental Health Sciences. Personnel from Lakeshore Technical College led development of this program. We are grateful to personnel at Discovery Designs Refrigeration for providing a graphic of a complete two stage system. We encourage you to comment on these materials. Please give your suggestions to those teaching the program in which you are now enrolled or click on 'contact us' at <https://mwc.umn.edu>.

## Warning

This material has been copyrighted by the Midwest Consortium for Hazardous Waste Worker Training. A recipient of the material, other than the Federal Government, may not reproduce it without permission of the copyright owner.

The material was prepared for use by experienced instructors in the training of persons who are or who anticipate responding to chemical emergencies. Authors of this material have prepared it for the training of this category of workers as of the date specified on the title page. Users are cautioned that the subject is constantly evolving. Therefore, the material may require additions, deletions, or modifications to incorporate the effects of that evolution occurring after the date of this material preparation.

## Disclaimer

The Occupational Safety and Health Administration (OSHA) standard to help ensure health and safety during emergency response activities requires specific training for members of the response team, depending upon the duties to be performed. This program is intended to assist the employer in meeting the requirements of the Technician-Level responder to ammonia releases at industrial sites. Employees trained at this level are permitted to approach the point of release of the ammonia to stop or reduce the flow. According to the regulation 29 CFR 1910.120(q)(6)(iii):

Hazardous materials technicians are individuals who respond to releases or potential releases for the purpose of stopping the release. They assume a more aggressive role than a first responder at the operations level in that they will approach the point of release in order to plug, patch or otherwise stop the release of a hazardous substance.

This program is not a full technician-level program, but rather one focused solely on anhydrous ammonia used in food processing. Additional training will be required for responders who may be responsible for controlling the release of other hazardous materials or ammonia in other employment sectors. In addition, annual refresher training is required by OSHA for all emergency responders.

This manual was updated August 29, 2023 and all web links are active as of that date; if

you find an error, please inform the facilitator so that it can be updated.

<b>Table of Contents</b>	<b>Page</b>
Course Introduction	1
Introduction to Ammonia Emergency Response	5
Chemical Properties of Ammonia	19
Toxicology and Health Effects	33
Personal Protective Equipment	45
Respiratory-Protective Equipment	46
Chemical-Protective Clothing	70
Other Protective Gear	93
Material Identification	97
Monitoring	121
Work Practices	147
Decontamination	165
Emergency Response	181
Tabletop	199
Level A or B Simulation with Full Decon Line	200
Cleanup and Critique (Termination)	202
Closing and Program Evaluation	204

## **Course Introduction**

---

Welcome to the anhydrous ammonia program, designed for emergency responders who may be assigned the task of controlling a release of this important refrigerant in food processing. Training is required in the Occupational Safety and Health Administration standard often referred to as HAZWOPER. This acronym stands for:

HAZ HAZardous  
W Waste  
OP OPerations and  
E Emergency  
R Response

You are participating in this training program because you are or will participate in a team of responders who are assigned to go to the point of a release of anhydrous ammonia and stop the emission following practices and procedures described in a written document initially developed during preplanning and updated routinely.

During this program you will learn skills to avoid exposure as you prepare to participate in responses to potential spills or releases of ammonia. Specific exercises include:

- Using resources to assess hazards
- Identifying hazard control measures
- Implementing standard operating procedures
- Selecting and donning/doffing provided personal protective equipment
- Using monitoring equipment to identify hazards
- Working within the Incident Command System
- Performing control, containment or confinement of a release
- Setting up decontamination procedures
- Participating in termination activities

The skills will be applied during an emergency scenario.

When you finish, you will be better able to:

- Recognize hazards of ammonia
- Contain a release
- Minimize exposure to ammonia
- Prevent the spread of the contaminant
- Describe practices to reduce potential emergencies
- Implement actions in the emergency response plan (ERP)
- Play a role in the Incident Command System (ICS)

Using some basic information (such as chemical hazards, health effects, regulatory requirements and safety terms) you will be introduced to and work with:

- Respiratory-protective equipment
- Chemical-protective clothing
- Information resources
- Monitoring equipment
- Plans, including a for-training-only emergency response plan

Each day includes time for review. Throughout the program, you are urged to ask questions. If an instructor does not have the answer to your question, the answer may be provided later or during a later part in the program. For example, a question on day 1 about an air sampler would likely be deferred to the day 2 monitoring session.

Sometimes instructors may place a question on a list posted in the room (called the 'parking lot'), so that it is not overlooked.

This program was developed by the Midwest Consortium for Hazardous Waste Worker Training, a group of trainers from nine states dedicated to interactive training to meet the needs of workers. The Consortium receives funding from the federal government (National Institute of Environmental Health Sciences, or NIEHS) to develop and present 'model' training programs. By this the government means that we have a certain number of instructors, include hands-on activities, and include methods to document the value of the training to participants through your feedback. In addition, we are required to define "successful completion" for the participants. This program includes a combination of several measures to achieve successful completion: a knowledge tests, exercises with checklists and attendance at all sessions. Pre- and posttests are used to measure knowledge gain during the course. Checklists are used during exercises to document skill proficiency. You are asked to sign in daily to document attendance.

### Get the Most from Training

Ask questions

Participate in small group discussions

Put your hands-on equipment and tools

Use resources

Learn from experiences of others

During this introductory session, you will:

- Use a local example to identify or illustrate response hazards
- Complete a pretest

The goal is to use work practices to minimize exposures to ammonia.

### **Recent Releases**

---

Your facilitator will introduce one or more recent ammonia releases and responses in the Midwest. What information or skills would have been useful to the responders?

### **Summary – Course Introduction**

---

The overall goals of the program were reviewed:

- Recognize hazards of ammonia
- Contain a release
- Minimize exposure to ammonia
- Prevent the spread of the contaminant
- Describe practices to reduce potential emergencies
- Implement actions in the emergency response plan (ERP)
- Play a role in the Incident Command System (ICS)

By reviewing a local example, the need for training prior to a response was illustrated.



# **Introduction to Ammonia Emergency Response**

---

Your responsibilities in emergency response to ammonia hazards builds on your previous work experience and health and safety training. By learning to use resources throughout this program, you will be able to find answers to questions that arise after the training program ends.

During this introductory session, you will:

- Review the format of the HAZWOPER regulation
- Use HAZWOPER to find and review a definition of Hazardous Material and Emergency Response
- Discuss advantages of response organization
- Described the limited scope of this program
- Review the OSHA Act and worker and employer rights and responsibilities

The goal is to use good work practices to minimize exposures to responders and others who may be affected by an ammonia release.

### The format of HAZWOPER

---

The standard commonly called HAZWOPER, or 29 CFR 1910.120, is the major federal regulation designed to safeguard the safety and health of workers responding to a chemical release and handling and disposing of hazardous materials. The standard is enforced by the Occupational Safety and Health Administration (OSHA); in some states, Federal OSHA has jurisdiction and in other states, state government has set up a state plan. Who covers HAZWOPER where you work?

Paragraphs in the standard are identified with numbers and letters to make it easier to locate the information, like how library books are numbered. For example, the specific requirements for training of technician-level responders are found in section 29 CFR 1910.120 (q)(6)(iii). In the illustration below, see how to interpret the numbering of the paragraph.

#### Requirements for Hazardous Materials Emergency Responder Training

##### **29 CFR 1910.120**

29	=	OSHA regulations are located in Title 29
CFR	=	<i>Code of Federal Regulations</i> is the title of the government publication
1910	=	Part number 1910 covers General Industry
.120	=	Section number 120 covers hazardous waste operations and emergency response
(q)(6)	=	The paragraph describes training for each level of emergency responder

### What is a Hazardous Substance?

---

There are various definitions of 'hazardous substance' found in laws and regulations.

Find the definition of 'hazardous substance' in the Definitions section of HAZWOPER.

OSHA defines 'hazardous substance' in 29 CFR 1910.120(a)(3) by reference to several lists:

- Section 103(14) of the Comprehensive Environmental Response Compensation and Liability Act (CERCLA) (42 U.S.C. 9601)
- Any substance listed by the U.S. Department of Transportation as hazardous materials under 49 CFR 172.101 and appendices
- Waste or combination of wastes as defined in 40 CFR 261.3, or substances defined as hazardous wastes in 49 CFR 171.8

And this broad statement: "Any biologic agent and other disease-causing agent which after release into the environment and upon exposure, ingestion, inhalation, or assimilation into any person, either directly from the environment or indirectly by ingestion through food chains, will or may reasonably be anticipated to cause death, disease, behavioral abnormalities, cancer, genetic mutation, physiological malfunctions (including malfunctions in reproduction) or physical deformations in such persons or their offspring."

The following, less technical definition may be helpful: A **hazardous substance/material** may cause damage to people, property, or the environment.

Why this broad definition? Some hazards affect the environment or are transmitted through the environment to a responder. And property damage may result from contact with the hazardous material or a fire.

A good, non-legal benchmark: When in doubt, treat any release as hazardous!

Ammonia is a hazardous material

### What is an Emergency Response?

---

OSHA defines a HAZWOPER Emergency Response as:

**Emergency Response** or responding to emergencies means a response effort by employees from outside the immediate release area or by other designated responders (i.e., mutual aid groups, local fire departments, etc.) to an occurrence which results, or is likely to result, in an uncontrolled release of a hazardous substance.

Responses to incidental releases of hazardous substances where the substance can be absorbed, neutralized, or otherwise controlled at the time of release by employees in the immediate release area, or by maintenance personnel are not considered to be emergency responses within the scope of this OSHA standard. Responses to releases of hazardous substances where there is no potential safety or health hazard (i.e., fire, explosion, or chemical exposure) also are not considered to be emergency responses by OSHA.

OSHA defines a **catastrophic release** of ammonia at facilities with 10,000 pounds or more (referred to as a threshold quantity) as: major uncontrolled emission...that presents serious danger to employees in the workplace. Where the threshold quantity is met, compliance with 29 CFR 1910.119, **Process Safety Management of Highly Hazardous Chemicals (PSM)** is required by OSHA.

Why do these definitions support that everyone should be trained at some level?

Because of training...

- Essential information is reported to the designated person
- Appropriate decisions can be made regarding actions
- Exposures to humans and environment are minimized
- Responders use appropriate PPE and work practices
- Follow-up is done to learn from each response

### How is a Response Organized?

Think about the local example(s) discussed earlier and your experience. Discuss several ways that an organized response might limit exposures to personnel and the environment.

The procedures used to determine if a response is needed and for any response actions are described in a plan. The name of this plan may vary; in HAZWOPER, it is called an Emergency Response Plan (ERP); in PSM it is called an Emergency Action Plan (EAP). Regardless of the name, the need for preplanning to create a detailed plan that is practiced is the same. This written Plan is an administrative control of hazards.

OSHA 29 CFR 1910.120(q)(2) is a list of elements that must be included in the ERP:

- Pre-emergency planning and coordination with outside parties  
In PSM, this pre-planning is described as a formal Process Hazard Analysis (PHA) to identify, evaluate and control hazards of use. See 29 CFR 1910.119(e). At least one employee familiar with the operation joins a team of engineers and process managers to conduct the PHA that is updated at least every five years; this update includes identifying previous incidents.
- Personnel roles, lines of authority, training and communication
- Emergency recognition and prevention
- Safe distances and places of refuge
- Site security and control
- Evacuation routes and procedures
- Decontamination
- Emergency medical treatment and First Aid
- Emergency alerting and response procedures
- Critique of response and follow-up
- Personal protective equipment and emergency equipment

The International Institute of Ammonia Refrigeration (IIAR) guidance includes Emergency Operations as a required element of overall Operating Procedures.

### Why an Ammonia-specific Program?

There are several levels of emergency response training shown in 29 CFR 1910.120(q)(6).

Awareness level is described in paragraph 29 CFR 1910.120(q)(6)(i). Awareness training prepares the participant to recognize an emergency and alert the appropriate personnel. Awareness-level training does not qualify the participant to take on any duties other than notifying authorized personnel who will implement a response.

Operations level is described in paragraph 29 CFR 1910.120(q)(6)(ii). Operations-level training provides the skills to assist in a response by conducting tasks that are defensive in nature—containing a release from a safe distance to keep the release from spreading, but not approaching to the point of release to stop further release.

Technician level is described in paragraph 29 CFR 1910.120(q)(6)(iii). Personnel trained to this level approach the point of emission to stop a release. Procedures and use of protective gear must be practiced in order to conduct an effective response, should one be needed.

Specific objectives of technician-level training are:

- Implement the emergency response plan
- Classify, identify, verify known and unknown materials using survey instruments
- Function within the assigned role in the Incident Command System
- Know how to select and use proper specialized PPE
- Use hazard and risk assessment techniques
- Perform advanced control, containment, confinement operations using available resources and PPE
- Understand and implement decontamination
- Understand termination procedures
- Understand basic chemical behavior and toxicology terms

These three levels of training build one upon each other. As you read through the standard, note that those who enter a technician-level program must have had ‘at least 24 hours of training equal to the first responder operations-level...’ and in addition (through technician training) develop the competencies shown for the technician-level. Hazardous materials specialists described in 29 CFR 1910.120(q)(6)(iv) are responders who are trained to contain a specific substance. They are able to implement the local

ERP and develop site safety and control plans.

On scene incident commanders 29 CFR 1910.120(q)(6)(v) assume control of an incident and have specific competencies needed for that management task as well as training at the operations level.

For all levels of emergency response training, it is the responsibility of the employer to certify that the competencies have been demonstrated by each person at the designated level of training.

Because your duties are limited to a single chemical hazard, ammonia, this program has been shortened from the usual 40-hour minimum to 24. For example, you will learn to don and doff protective gear for ammonia only, not how to select gear for a range of chemical hazards. Should your duties expand to other hazards, additional training is required to provide proficiencies in the broader scope of emergency response.

### **Review – the OSHAct and Worker and Employer Rights and Responsibilities**

#### **OSHAct**

The Occupational Safety and Health Act (OSHAct) of 1970 is a major law concerned with worker health and safety. It was passed to prevent workers from being killed or seriously harmed at work. The law requires employers to provide their employees with working conditions that are free of known dangers. The Act created the Occupational Safety and Health Administration (OSHA), which sets and enforces protective workplace safety and health standards. OSHA also provides information, training and other assistance to workers and employers. Regulations set by OSHA are published in Section 29 of the Federal Register, with Part 1915 reserved for maritime industries, Part 1910 for general Industry, and Part 1926 for the construction industry.

OSHA covers private sector employers of all sizes in all 50 states, the District of Columbia, and other U.S. jurisdictions. Small employers (fewer than 10 employees) are exempted from some injury record-keeping requirements (29 CFR 1904). Laws are administered by federal OSHA or through an OSHA-approved state program. State-run health and safety programs must be at least as effective as the Federal OSHA program. To find the contact information for the OSHA Federal or State Program office nearest you, see the Regional and Area Offices map at <http://www.osha.gov/html/RAmap.html>.

Employees who work for state and local governments are not covered by Federal

OSHA but have OSHA Act protections if they work in a state that has an OSHA-approved state program. Four additional states and one U.S. territory have OSHA approved plans that cover public sector employees only: Connecticut, Illinois, New Jersey, New York, and the Virgin Islands. Private sector workers in these four states and the Virgin Islands are covered by Federal OSHA.

Federal agencies must have a safety and health program that meets the same standards as private employers. Although OSHA does not fine federal agencies, it does monitor federal agencies and responds to worker complaints.

Those not covered by the OSHA Act include the self-employed, immediate family members of farm employers that do not employ outside employees, and employees at workplaces regulated by another Federal agency (for example, the Mine Safety and Health Administration, the Federal Aviation Administration, the Coast Guard).

In addition to setting standards such as HAZWOPER and Hazard Communication (HazCom), OSHA is charged with:

- Inspecting workplaces to ensure standards are being met
- Issuing citations and fines to companies that do not meet the standards
- Overseeing state plans for safety and health
- Encouraging the development of training programs for workers, management, and health professionals

### **Worker Rights under the OSHA Act**

You have several rights under the Act. Detail is shown at the OSHA website, [www.osha.gov](http://www.osha.gov)-click on You have the Right to a Safe Workplace.

A brief summary is provided below:

#### **Your Right to Have an Inspection of a Workplace**

A worker can notify OSHA of a potential hazard by completing the OSHA Notice of Alleged Safety or Health Hazards form, often called a 'complaint form'. Once a complaint is received at the OSHA Office, it will be assigned to one of their compliance officers.



The inspection priority defined by OSHA is:

- Imminent danger
- Catastrophic (a fatality or three or more workers are hospitalized overnight as a result of an on-the-job exposure)
- Complaint inspection (filed by a worker or worker representative)
- Scheduled inspection (general OSHA inspection not because of a complaint or catastrophe, but because injury statistics show that the employer has more injuries and illness than similar employers)
- General inspection or “pick of the hat.” (Previously inspected sites are pooled, and through random selection, two sites are drawn and visited each year)

Note that complaints are high on the priority list. More information and the form are available online ([https://www.osha.gov/workers/file\\_complaint.html](https://www.osha.gov/workers/file_complaint.html)). A complaint can be filed anonymously. You can also discuss concerns with the local OSHA office; current phone contact information can be found using the telephone icon on the same website.

### **Your Right to Participate in the OSHA Walk-Around Inspection**

Through an employee organization such as a union or joint health and safety committee, an employee representative is designated to accompany the OSHA compliance officer in the walk-around inspection. It should be noted that OSHA regulations currently do not require the employer to pay the employee for time spent on the OSHA walk-around; however, some states with an OSHA plan require employees to be paid for the time spent during a walk-around. Walk-around activities include all opening and closing conferences related to the conduct of the inspection but do not include any post-citation appeal procedures.

### **Your Right to Be a Witness or to Give Information**

Every employee has the right to appear as a witness at an OSHA hearing. During the walk-around inspection, or before or after the inspection for that matter, any employee has the right to provide OSHA with any information regarding possible safety and health hazards. This right is protected by law.

### **Your Right to Be Informed of Imminent Dangers**

All employees have the right to be informed by the OSHA compliance officer if it is determined that they are exposed to an imminent danger (one which could cause death or serious injury now or very soon). The compliance officer will also ask the employer to

stop the work process voluntarily and remove the employees. If the employer refuses to stop the work process upon the request of the compliance officer, a judge can force the employer to do so if necessary.

### **Your Right to Be Told About Citations**

Notices of OSHA citations must be posted in the workplace near the site where the violation occurred and must remain posted for three days or until the hazard is corrected, whichever is longer. Citations and penalty notifications can be requested from the OSHA Area Office. When an OSHA industrial hygiene inspection has taken place, the hygienist's report, which includes substances collected, procedures used, and measurement results, may also be obtained by the employees, their representatives, or their union upon request.

### **Your Right to Appeal OSHA Performance**

If OSHA fails to perform in a responsible and timely manner, the employees, employer, or union has the right to meet with the OSHA Area Director and the OSHA Regional Administrator. Any of these groups may ultimately appeal to the Secretary of Labor.

### **Your Right to Appeal Abatement Dates (When a Violation Must Be Fixed)**

The findings of the OSHA office may be appealed within 15 working days of the issuance of the citation to the employer. The right to contest the citation is limited only to the question of the reasonableness of the abatement period of the citation. Employees or their organization cannot contest the penalty amount or the citation itself.

### **Your Right to Have a Closing Conference After an Inspection**

Employees have the right to meet privately with the OSHA officer and discuss the results of the inspection. OSHA procedures state that the OSHA inspector must inform the employers and employees that a generally responsive discussion covering general issues will be held.

### **Your Right to Know of Health Hazard Exposures**

Employees have the right to be notified if exposed to occupational health hazards and to be notified of the results of occupational health studies conducted by the employer or OSHA. The employees or their organization can and should ask for any and all instrument readings or levels of contaminants found. A copy of the lab report should also be requested from OSHA. These documents are normally available upon request but may also be obtained by any member of the public pursuant to the Freedom of Information Act.

### **Your Right to Have Access to OSHA Records**

Most OSHA records are available upon request. The employees, or their organization, should contact the OSHA Area Office where the plant is located.

### **Your Right to Participate in Development of New Standards**

Every employee has the right to participate in the development of new safety and health standards or modification of old codes through his or her employee organization. Individuals may also comment on proposed standards during open periods of comment.

### **Your Right to Review a Citation Procedure When a Citation Is Not Issued**

Every employee has the right to request an informal review when a citation is not issued or for any other issue related to an inspection, citation, notice of proposed penalty, or notice of intention to contest a citation. A written statement as to why a citation was not issued may be requested.

### **Your Right to File a Discrimination Complaint**

If an employee has been discriminated against as a result of exercising his or her rights under OSHA, that employee has the right to file a complaint with the OSHA Area Office within 30 days. This time limit is strictly enforced. Similar rights to file a complaint may exist with state and local anti-discrimination agencies, as well as the employee organization.

### **Worker Responsibilities under OSHA**

You also have responsibilities under the Act, as summarized below:

#### **Your Responsibility to Abide by Established Safety Rules**

Workers cannot be cited or fined by OSHA, but employers can take disciplinary action for violation of established safety rules.

#### **Your Responsibility to Wear and/or Use Required Safety Equipment**

Workers are responsible for wearing and/or using required safety equipment.

#### **Your Responsibility to Seek Prompt Medical Treatment When Required**

Workers should seek medical treatment promptly when required. Depending on applicable state law, workers have a right to be treated by a physician of their own choice for work-related injuries. Do not delay medical treatment when necessary.

### **Your Responsibility to Bring Safety and Health Concerns to the Attention of Management**

Workers should bring safety and health hazards or concerns to the attention of their supervisors or forepersons as soon as possible. If the workers are organized, then they may want to ask the representative to bring the issue to the attention of management.

### **Your Responsibility to Pay for Gear That Can Be Worn Off the Job**

Workers must pay for ordinary safety footwear, ordinary prescription safety eyewear, logging boots, and ordinary clothing and weather-related gear that can be worn off the job.

### **Employer Rights and Responsibilities under the OSHA Act and regulations**

Employer rights and responsibilities are described in an OSHA publication shown at <https://www.osha.gov/Publications/osha3000.pdf> and are summarized below:

#### **Employer Rights**

##### **Employer Rights following an OSHA inspection**

If a worksite inspection is conducted, the employer has rights to an informal conference to discuss the apparent violations, to contest the citation and to petition for a modification of abatement dates. See <https://www.osha.gov/Publications/fedrites.html>.

#### **Employer Responsibilities**

##### **Employer Responsibility to Furnish a Safe and Healthy Job and Work Environment**

The employer must furnish each employee a job and a place of employment free from recognized hazards that are likely to cause death or serious physical harm. This responsibility is commonly referred to as the “general duty clause” of the Act. It describes the overall or general responsibility of the employer not to expose employees to harmful situations or chemicals.

##### **Employer Responsibility to Pay for Personal Safety Equipment**

The employer must pay the full cost for most required personal protective equipment (PPE) used to comply with OSHA standards, except for safety gear that can be used off the jobsite (such as some safety shoes).

### **Employer Responsibility to Comply with OSHA Standards**

Employers must comply with applicable parts of the OSHA General Industry Standards (1910) and the Construction Industry Standards (1926), including HAZWOPER (1910.120). HAZWOPER applies only to hazardous waste and treatment/storage/disposal operations and emergency response. In the event of a conflict between HAZWOPER and a more the general standard, the most protective must be enforced.

### **Employer Responsibility to Report Fatalities and Injuries**

Employers must inform OSHA of any fatality within 8 hours of the event. The employer must inform OSHA of any injury requiring inpatient hospitalization, an amputation, or any loss of an eye within 24 hours.

### **Employer Responsibility to Maintain Records of Injuries**

Under the OSHAct, all employers with more than 10 employees must maintain a log of injuries and make it available to OSHA compliance officers upon request. Each year the employer must post an annual summary of the injury log for the information of the employees. This form is called the OSHA 300A and must be displayed each year for the months of February, March, and April (see <https://www.osha.gov/recordkeeping/RKforms.html#>). The employer must also display the required OSHA poster, which outlines specifics of the OSHAct (see <https://www.osha.gov/Publications/osha3165.pdf>). Do you know where these are posted at your workplace?

Employers are required to record information about specific occupational injuries and illnesses. Every occupational death and non-fatal illness must be recorded on the OSHA log. Other non-fatal injuries which must be recorded include loss of consciousness, restriction of work motion, transfer to another job, or medical treatment other than First Aid.

Contact your local OSHA office with questions about recordable illnesses and injuries.

### Employer Responsibility to Post Information

The official OSHA *Job Safety and Health – It's the Law* poster that describes rights and responsibilities must be posted prominently in the workplace at all times. Download it here: <https://www.osha.gov/Publications/poster.html>.

Any citation for apparent violations received from OSHA must be posted until the items are resolved where workers can see each page.

The annual summary of injury and illness data must be posted where workers can see the form during the months of February, March and April of each year.

### Employer Responsibility to Not Retaliate

If a worker exercises rights under the law, including the right to report a work-related injury or illness, the employer must not retaliate.

See also <https://www.osha.gov/as/opa/worker/employer-responsibility.html>.

### **Summary – Introduction to Ammonia Emergency Response**

During this session, participants:

- Reviewed the format of the HAZWOPER regulation
- Used HAZWOPER to find and review a definition of Hazardous Material and Emergency Response
- Discussed advantages of response organization
- Described the limited scope of this program
- Reviewed the OSHA Act and worker and employer rights and responsibilities

The procedures used to determine that a response is needed and for the conduct of the response are described in the Emergency Response Plan (ERP) if the actions are conducted under HAZWOPER. When plant personnel also comply with Process Safety Management, plan is called an Emergency Action Plan (EAP). In practice, the terms may be used interchangeably - be sure you know what to do if a release occurs, regardless of the name of a plan!

NOTE: EAP is also referenced in OSHA 29 CFR 1910.38 Emergency Action Plans for workplaces where employees evacuate, and the response is conducted by outside personnel. This requirement is not included here, where the focus is on response.

# Chemical Properties of Ammonia

---

Many types of chemicals may be found in industry or along transportation routes. However, this program is organized for response to a single hazard: ammonia. Responders who can recognize and describe the properties of ammonia are better able to reduce exposures and avoid injury or illness.

## Learning Objectives

---

When you have completed this section, you will be better able to:

- Describe the importance of basic chemical terms relevant to ammonia
- Identify special characteristics of ammonia that impact responders
- Demonstrate an ability to find properties of ammonia using resources

## Chemical Properties

---

In this section, some basic chemical terms and properties relevant to ammonia and ammonia releases illustrated.

### Important Terms

Chemistry is the study of the properties of chemicals and the changes that occur when different materials are mixed, heated, or exposed to extreme pressure or temperature.

Chemical: Ammonia is a chemical made up of two elements, nitrogen (N) and hydrogen (H) with a chemical formula of  $\text{NH}_3$ .

Ammonia is in the category of inorganic chemicals, generally referring to chemicals that do not contain carbon (C). (But there are exceptions to this general guideline such as the inorganic chemical carbon monoxide,  $\text{CO}$ .)

Chemicals may be identified on a label or in company data files by the Chemical Abstracts Service (CAS) name, a synonym, a trade name or a manufacturer name. Product literature and other resources often show all names. Ammonia, anhydrous ammonia and ammonia anhydrous are synonyms.

When ammonia is dissolved in water heat is released and the resulting compound is ammonium hydroxide,  $\text{NH}_4\text{OH}$ , a very different chemical as shown by the formula and the unique numbers CAS assigns:

Anhydrous Ammonia	CAS number 7664-41-7
Ammonium Hydroxide	CAS number 1336-21-6

This program addresses anhydrous ammonia.

References to ammonia throughout the program are to anhydrous ammonia.

Many properties of a chemical depend on temperature and pressure. The conditions at which the property is measured will be noted to be NTP or STP.

**NTP:** Normal Temperature and Pressure (room conditions) 68°F or 20°C; 1 atmosphere or 760 mmHg (millimeters of mercury, Hg)

**STP:** Standard Temperature and Pressure 32°F or 0°C, 1 atmosphere or 760 mmHg



## Chemical Properties of Ammonia

Selected chemical properties relevant to ammonia and ammonia compounds are defined and illustrated below.

**BP** (Boiling Point). The temperature above which a liquid when heated to 'bubbling' at a specified pressure will evaporate rapidly. See the illustration showing ice changing to water (melting point) and to a vapor (boiling point); at sea level, water boils at 212°F.

Anhydrous ammonia boils at -28°F, well below freezing, 32°F. At NTP and STP it is a colorless gas. When ammonia changes from a liquid to a vapor (boils) the vapor cloud may appear white due to condensation in the air. During a release into the environment this process will extract heat from surrounding air and surfaces, rapidly lowering the temperature.

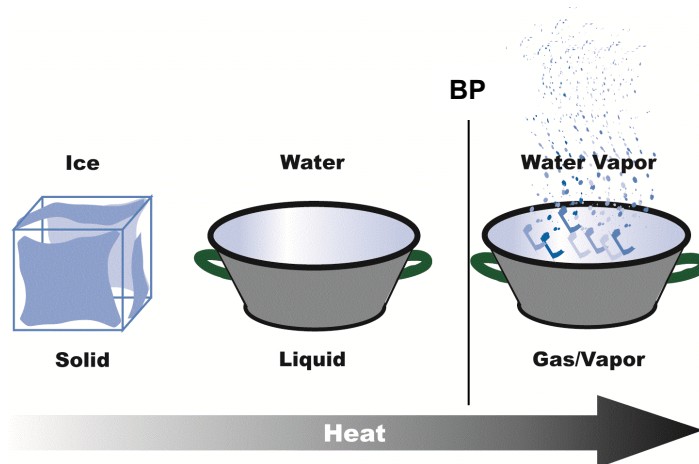

**VP** (Vapor Pressure) in millimeters of mercury (mmHg). In a closed system, the pressure exerted by a vapor in equilibrium with the solid or liquid form. The vapor pressure increases with increasing temperature. VP is usually measured at 68°F at the reference pressure of 760 mmHg (1 atmosphere, 1atm). The higher the VP, the faster the chemical evaporates into space. See an illustration of vapor pressure on right for two chemicals at the same temperature.

Anhydrous ammonia has a VP of 8.5 atm, much greater than 1 atm—so it is a gas at atmospheric pressure, unless compressed and contained in a vessel.

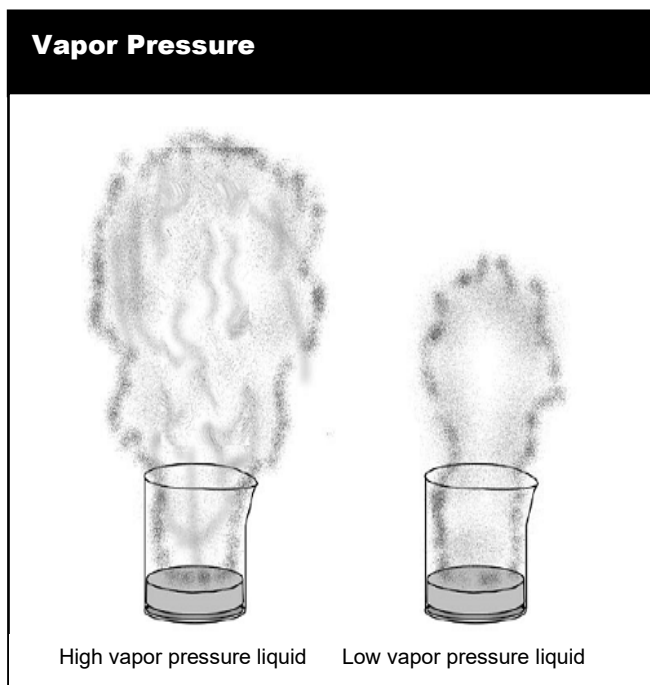

**Sp.Gr.** (Specific Gravity). As a ratio of density of equal volumes of one substance compared with density of another at a specified temperature, Sp.Gr. has no units. Usually water is the comparison and the measurement is made at 68°F. If a chemical

## Chemical Properties of Ammonia

has a higher density than the reference compound, it will sink (Sp. Gr. greater than 1). If a chemical is less dense than the reference (the Sp. Gr. is less than 1) it will rise when mixed with the reference compound.

Anhydrous ammonia liquid has a specific gravity of 0.62; the gas has a specific gravity of 0.59. The usual layering will not be observed as anhydrous ammonia is a gas at NTP and STP but be aware that it will collect at the ceiling or top of an unpressurized container.

**RGasD** (Relative Gas Density of vapor compared to air=1). RGasD greater than 1 indicates the chemical is heavier than air; RGasD less than 1 indicates the chemical is lighter than air. If you know the molecular weight (MW) of the chemical, calculate the RGasD as  $MW/29$ . See an illustration of relative gas density below.

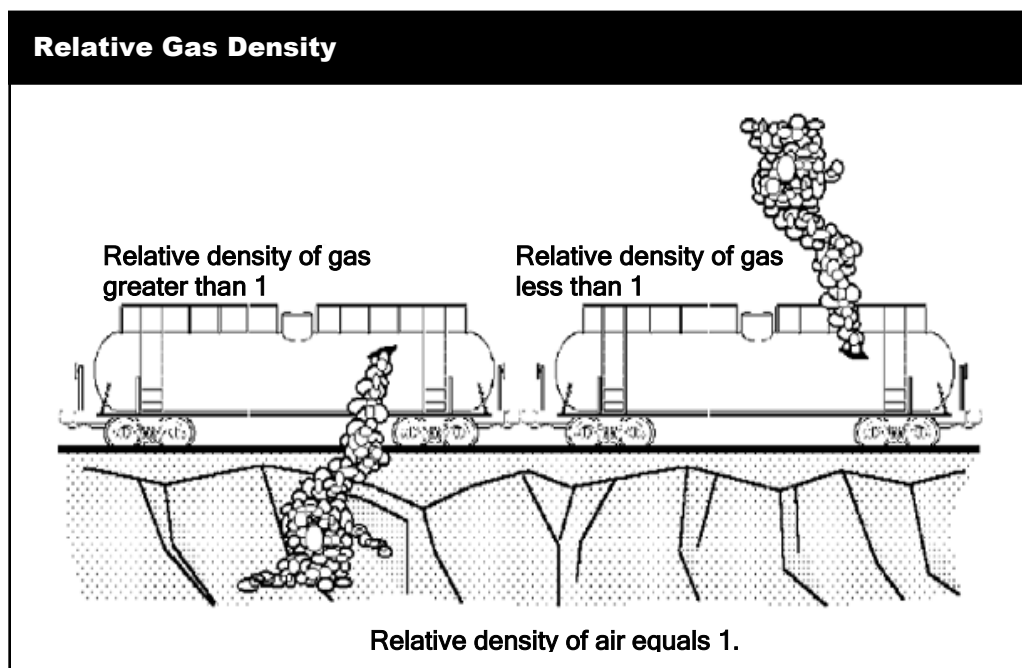

Anhydrous ammonia has an RGasD value of 0.6.

NOTE: Several typically reported chemical properties are difficult to determine or not determined for anhydrous ammonia.

Flash point (**FI.P.**), the temperature at or above which there is enough vapor of a liquid chemical to ignite if an ignition source is applied is generally provided for liquid

## Chemical Properties of Ammonia

chemicals. The usual test methods are not appropriate for anhydrous ammonia, for which a specialized test chamber is required. Most resources do not report a value for anhydrous ammonia.

Evaporation rate (**ER**) and freezing point (**FP**) are not reported. See a representative Safety Data Sheet and other resources provided by the facilitator for the exercise in this part of the program.

Dissociation is the term used to describe the breaking apart of a compound into smaller components. At approximately 800°F, anhydrous ammonia dissociates into nitrogen (N<sub>2</sub>) and hydrogen (H<sub>2</sub>). The hydrogen can result in a flash or burn hazard.

Expansion Ratio or Volume Expansion Ratio (VER). A unit-less ratio of the volume filled by the gas compared to the confined, liquefied gas. For anhydrous ammonia this ratio is 850.

Rapid heating has resulted in large emergency response efforts.

Critical Temperature (T<sub>CR</sub>) is the temperature at which no amount of pressure will liquefy a gas. For anhydrous ammonia the critical temperature is 270°F. Should a fire or other event occur that raises the temperature above the critical value, the housing of a liquefied gas poses an extremely dangerous hazard.

At 68°F, anhydrous ammonia exerts a pressure of approximately 110 pounds per square inch (psi) in a closed system. Compare this pressure with VP of greater than 760 mmHg described above (760 mmHg is approximately equal to 15 psi).

What is the physical form of ammonia at a release from a closed system?

....it depends on where in the system!

Gas

Liquid

Aspirated liquid (droplets)

## Chemical Properties of Ammonia

Solubility (**Sol**) or the ability of a gas to dissolve in water varies with temperature and pressure. The effect of temperature on the solubility of anhydrous ammonia in water is shown below:

Temperature (°F)	grams of anhydrous ammonia in 100 grams of water
32	90.0
68	51.0
212	7.4

Anhydrous ammonia is very soluble in water, resulting in the chemical sometimes being referred to as 'water loving'. A typical strong ammonium hydroxide solution is 28-30% anhydrous ammonia.

Combined effect of water and expansion ratio

Anhydrous ammonia + water results in two reactions



heat of reaction + heat of  $\text{H}_2\text{O}$  → rapid expansion

The result can appear explosive (remember the expansion ratio is 850:1).

pH (Hydrogen ion concentration). The pH of a substance indicates if it is an acid or a base.

Bases are also referred to as alkali, alkaline or caustic. Acids have low pH, and bases have high pH. Strong acids and strong bases are corrosive, meaning that they are very damaging to container materials, surfaces, skin, eyes and lungs.

A strong acid and a strong base are incompatible and must never be mixed. A dangerous reaction will occur with a lot of heat produced and possible splashing. If they are mixed in a closed container, an explosion could result.

Anhydrous ammonia is a gas at NTP and STP and has no pH; however, when mixed with water the pH is very corrosive as shown by the example of household ammonia on the pH scale shown on the next page. When anhydrous ammonia contacts water in or on tissues (eyes, mouth/lungs, skin) the mixture is extremely corrosive, and the pH could be as high as 14.

## Chemical Properties of Ammonia

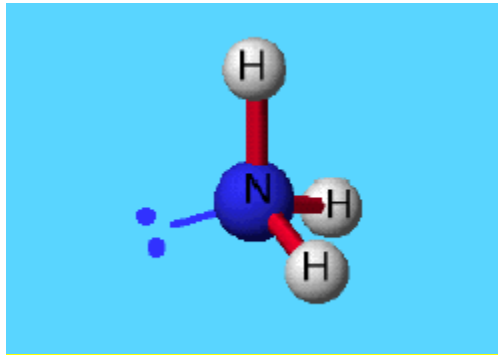

Source: [https://www.osha.gov/SLTC/etools/ammonia\\_refrigeration/ammonia/index.html](https://www.osha.gov/SLTC/etools/ammonia_refrigeration/ammonia/index.html).

## Chemical Properties of Ammonia

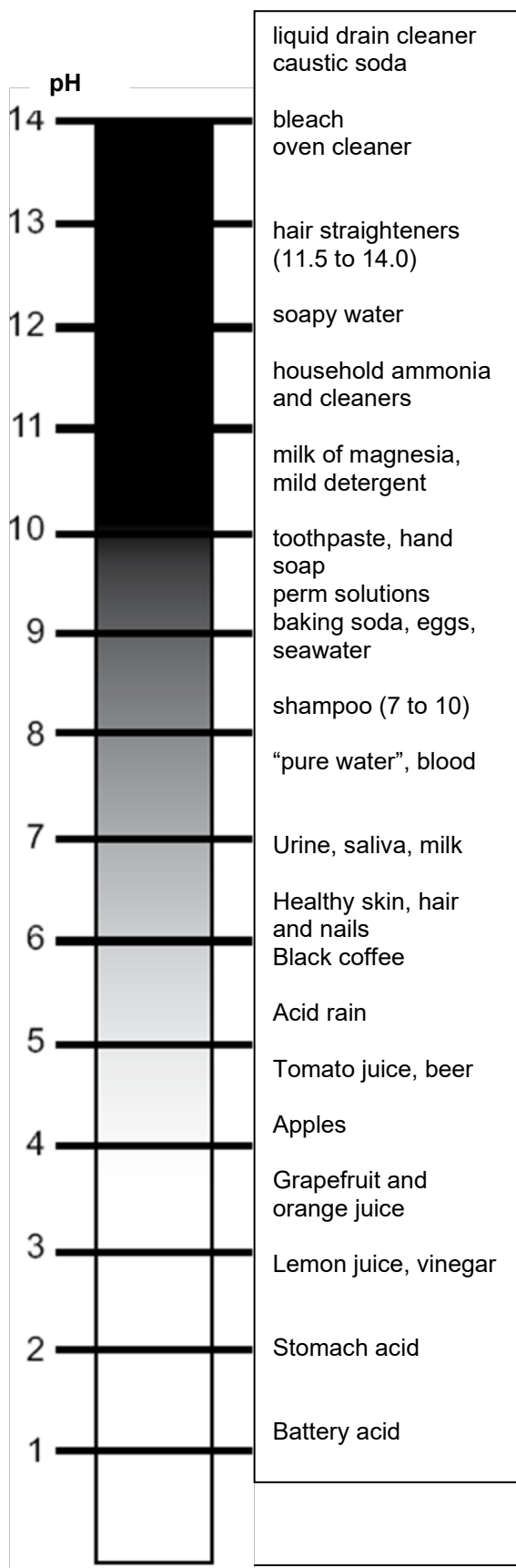

### Definition

Hydrogen ion concentration (pH) is used to determine if a substance is an acid or a base. A pH of 1 is very acidic; a pH of 14 is very basic (or alkaline).

Because of the very large range in the values of pH, a special scale has been created.

A one unit change in pH (for example, from 3 to 4) represents a 10-fold change in acidity or alkalinity.

### Example

See scale.

### Importance

Compounds with high and low pH cause burns, and irritate eyes, nose and lungs.

Substances with a pH less than or equal to 2 or greater than or equal to 12.5 are legally defined as hazardous waste.

Materials with a pH less than 2.0 or greater than 12 will burn skin, eyes and lungs.

### Incompatible Chemicals

Chemical combinations can be dangerous when the chemicals involved are incompatible, like strong acids and bases. Incompatible chemicals react violently when they come in contact. They may become more volatile and react due to an environmental change such as a temperature increase. Reactions of incompatible materials may result in heat, fire, explosion or a release of toxic gas.

Anhydrous ammonia is incompatible with several elements and compounds, including:

- Cyanides
- Oxidizing agents (examples: perchlorates, peroxides, permanganates, chlorates, nitrates)
- Dimethyl sulfate
- Metals (examples: gold, silver, mercury, copper, zinc) and their alloys (example: brass)
- Halogens (examples: fluorine, chlorine, bromine) and halogenated compounds
- Acids

Anhydrous ammonia and mercury, gold oxides or silver compounds can form pressure- and temperature-sensitive combinations that are explosive.

Incompatible chemicals must be stored away from each other and protected from coming into contact if the containers leak or rupture.



source:

[https://www.osha.gov/SLTC/etools/ammonia\\_refrigeration/receiving/index.html](https://www.osha.gov/SLTC/etools/ammonia_refrigeration/receiving/index.html)

### Explosive Limits

When the mixture of air and gasoline in an engine is too lean (not enough gas), the engine will not run. If the engine floods (too much gas or too rich), the engine will not run. When the mixture is right and the spark plugs are working, the gas/air mixture burns and the engine fires.

When there is just enough gas or vapor in the air to ignite, the concentration is at the Lower Explosive Limit (**LEL**, % in air). As the concentration of chemical in the air increases, it will reach a point where there is too much to support combustion. This concentration is called the Upper Explosive Limit (**UEL**, % in air). These limits may also be called the Lower Flammable Limit (**LFL**) and Upper Flammable Limit (**UFL**).

The Explosive Range (**ER**) or Flammability Range (**FR**) is the concentration of a substance in air between the LEL and the UEL. In this range, the substance will readily ignite.

When concentrations in an area are higher than a certain percentage of the LEL (guidelines may vary from employer to employer), the area must be evacuated. During an emergency or operation involving flammable/explosive gases or vapors, constant air monitoring is essential because the concentration can change rapidly. The air must be monitored not just in the immediate areas of the release but in any area that may potentially be contaminated.

For anhydrous ammonia:

LEL	15%	
UEL	26-28%	(varies by source)
ER or FR	15-28%	(showing upper value of UEL for ammonia)

### Fire Tetrahedron/Pyramid: Fuel, Oxygen/Oxidizing Agent, Heat, and Chemical Reaction

For a fire to burn, there must be four things: fuel (which may be a flammable vapor), oxygen from the air or other source (such as an oxidizer), heat (or source of flame or spark), and a self-sustaining chemical reaction. These four items make up the fire tetrahedron or fire pyramid. The four-sided fire tetrahedron helps predict situations that may result in fire. To put out a fire, one or more of the four elements must be removed.



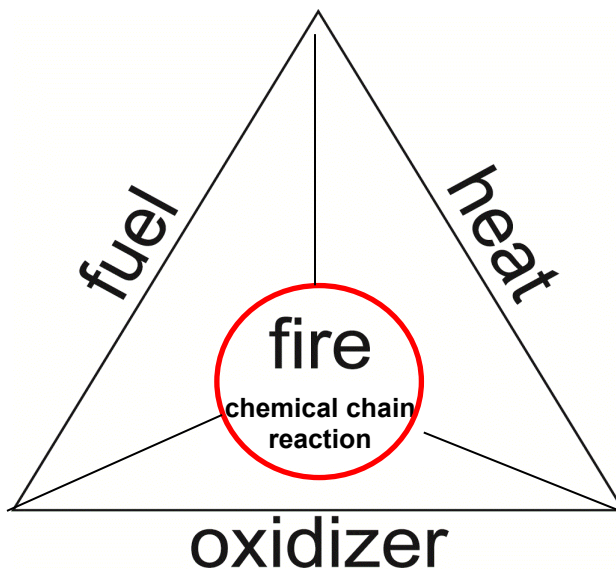

The addition of the chemical chain reaction allows for the update of the long-used fire triangle to the four-sided pyramid-shaped figure. The base of the pyramid is the chemical chain reaction that causes combustion. The sides of the pyramid—fuel, oxidizer and heat—are the elements of the older fire triangle.

Despite the undefined or unreported flash point determination, anhydrous ammonia will burn. See: <https://www.firehouse.com/rescue/article/10545372/handling-anhydrous-ammonia-emergencies> and <https://cameochemicals.noaa.gov/chemical/4860>.

Anhydrous ammonia used in refrigeration may contain oil from the compressor system. Depending on the source of any leak or emission, there may be aspirated oil (small droplets) in the atmosphere that changes the fire risk.

Air monitors filter out these particles of oil and thus do not provide any warning of the added risk.

Very close to a source of emission, the anhydrous ammonia may also appear as very small droplets; these may rapidly evaporate to a gas and affect the LEL reading.

### Toxic Products of Combustion

Fires can also create hidden dangers in the form of chemicals that are given off when products burn. Products such as furniture, pipes, wall coverings, and insulation materials may contain chemicals that can give off deadly gases and fumes when burned.

Burning anhydrous ammonia forms oxides of nitrogen that are hazardous to eyes and the respiratory and cardiovascular systems.

### Weather as a factor in behavior of ammonia at a release

Fog, high humidity, rain or cold temperatures are conditions under which a vapor cloud may be kept close to the ground, despite the RGasD value (<1). Some weather conditions can cause a plume to rapidly come down close to ground level; the potential occurrence of a 'bounce down' requires diligent observation.



<https://www.mda.state.mn.us/ammonia-incident-summaries>

### Video – Properties of Ammonia during a Release

---

A video of an ammonia release will be shown. Discuss what you see in the film, identifying chemical properties and any actions that may be of interest (safe and potentially unsafe).

### Exercise – Using the NIOSH Pocket Guide to find Chemical Properties

---

The NIOSH Pocket Guide to Chemical Hazards (NPG) is an important resource. (See <http://www.cdc.gov/niosh/npg/npgd0070.html>). In this exercise, you will use the NIOSH Pocket Guide to look up the properties of ammonia. (See Exercise Manual)

Not all the properties described above are included in the NPG (e.g., pH), but most are. When using the NPG, it is important to refer to the Definitions sections. Another useful resource is Cameo Chemicals (<https://cameochemicals.noaa.gov/>) which may be used in a later exercise.

### Summary – Chemical Properties

---

Anhydrous ammonia releases and reactions can cause harm to people and the environment.

Knowing the properties of this chemical helps to predict their behavior in the environment. These include:

- Boiling point (BP)
- Vapor Pressure (VP)
- Specific gravity (Sp. Gr.)
- Relative gas density (R<sub>GasD</sub>)
- Dissociation
- Volume Expansion ratio (VER)
- Critical temperature (T<sub>CR</sub>)
- Acid, base (pH)
- Solubility (Sol)
- Lower and Upper Explosive Limits (LEL, UEL)

The fire tetrahedron shows the four elements necessary for a fire to burn:

- Fuel (can be solid, liquid, or a flammable vapor)
- Heat (spark or fire source)
- Oxygen from the air or a chemical oxidizer
- Chemical reaction

It is very important to know these properties in order to respond safely.

Special properties of ammonia to consider include:

- Incompatibilities
- Toxic products of combustion
- Low boiling point
- High expansion ratio
- Solubility
- Effects of weather

Note: Flash point (F.I.P.), Evaporation Rate (ER) and Freezing Point (FP) are generally not provided for ammonia.

The NIOSH Pocket Guide to Chemical Hazards (<https://www.cdc.gov/niosh/npg/>) is a useful resource. It is available as an app for use on mobile devices.

## **Toxicology and Health Effects**

---

Toxicology is the study of physical and chemical agents that damage humans, animals, and/or the environment. Knowing some of the basic terms of toxicology is helpful in determining if and how exposure to ammonia can affect your health.

### **Learning Objectives**

---

When you have completed this section, you will be better able to:

- Identify several principles of toxicology important in ammonia exposure
- Identify human responses to ammonia exposures
- List reasons why medical surveillance is important to emergency responders
- Describe privacy of medical information
- Demonstrate an ability to find health effects of ammonia exposure using resources

### Introduction

---

How does the body react to exposure?

Have you ever inhaled second-hand cigarette smoke? What reaction did you have: throat and airway irritation, nausea, dizziness? Did your eyes burn from being in a room filled with smoke?

Do you, or does someone you know, have a runny nose and red eyes during “pollen season”?

Have you ever consumed too much alcohol (ethanol or ethyl alcohol)? Did you experience slurred speech, dizziness, nausea, vomiting, “passing out,” and/or a hangover complete with headache?

These are examples of responses of the body to an exposure. The effect was felt rapidly in each of these examples.

### Exercise – Using Resources to find Health Effect information

---

In this exercise you will use the resources provided to find health effect information for ammonia. Complete the worksheet, in small groups. (See Exercise Manual). If you are unfamiliar with a term used on the worksheet, use the resources shown below as you work through the exercise.

### Some Basic Principles of Toxicology

---

The health effects due to exposure to a hazardous substance can occur immediately or soon (acute) or be delayed for months or years (chronic).

#### Acute Effects or Acute Toxicity

An acute health effect means that the body’s response occurs at the time of exposure or within a few hours or days. Acute effects may result from a single exposure to a high concentration of a substance for a short period of time as in an accidental chemical release.

Examples of acute health effects include:

- Choking or coughing
- Nausea
- Dizziness
- Burning eyes, throat, or skin

Choking, coughing and burning of the eyes, throat or skin are all acute effects of ammonia exposure. Note that liquid on the skin that feels like a burn is really a freeze effect as heat from the body is used to vaporize the liquid.

After recovery from an exposure you may have no evidence of damage or may have temporary or permanent damage.

You may move away from an acute exposure if you experience a warning property. Warning properties of ammonia exposure include:

- Irritation to the skin, eyes, or respiratory tract (upper airways or lungs)
- Bad/unpleasant smell (but don't depend on your nose to alert you)

Warning properties cannot be relied upon to provide adequate protection from harm

Example: Contact with many hazardous materials cause irritation or inflammation of tissues. Any response should be reported to the appropriate person in the response structure, so that the cause can be identified. These reactions do not mean the exposure is to ammonia.

Example: For ammonia, the odor threshold, the lowest concentration that most people can detect, is about 5 ppm. Some people can detect a lower concentration, and others may become unable to smell ammonia at even higher concentrations after many exposures (sometimes referred to as 'desensitized'). Those with a bad cold have a more limited ability to smell; medical conditions or medications also may alter the sense of smell.

### Chronic Effects or Chronic Toxicity

A chronic health effect is one that is recognized months or years after the exposure. Chronic effects generally involve repeated or prolonged exposure. There are varying opinions regarding chronic effects following repeated ammonia exposures. In one animal study, a decreased appetite and weight loss resulted from repeated exposures. Some resources list lung effects from repeated exposures resulting in inflammation, including allergy or asthma reactions.

There are no data showing ammonia causes cancer, reproductive effects or mutagenicity.

### Routes of Entry

---

The way a harmful material enters the body is called the “route of entry”. Of the four routes of entry below,

- Inhalation affecting the respiratory tract (nose, upper airways, lungs)
- Skin (Skin and eye direct contact or absorption)
- Mouth to stomach (ingestion)
- Injection (skin puncture)

Inhalation and skin are the primary routes of entry for ammonia. It is unlikely that ingestion will occur in the work setting. A skin puncture from a high-pressure release is also unlikely.

#### Inhalation

Ammonia in the air as a gas or vapor may be inhaled. On contact with the water in the respiratory tract, ammonium hydroxide is formed, a very corrosive chemical that will cause inflammation of the tissues.

#### Skin/Eye Contact or Absorption

The unprotected skin is a major route of exposure to ammonia.

Liquid ammonia will freeze the skin, destroying the barrier and allowing contact with the blood. As with the respiratory tract, ammonia will react with water to cause further damage. Ammonia gas or vapor contacting sweat on skin will react to form ammonium hydroxide and cause burns.



## **Factors That Influence the Body's Response to Exposure**

Chemicals can cause varying responses at different concentrations. This is known as a **dose-response relationship**. (See the illustration below).

A chemical is considered relatively nontoxic if a large amount of a chemical (dose) is needed to cause an adverse health effect. The chemical is considered highly toxic if a small amount causes an adverse health effect.

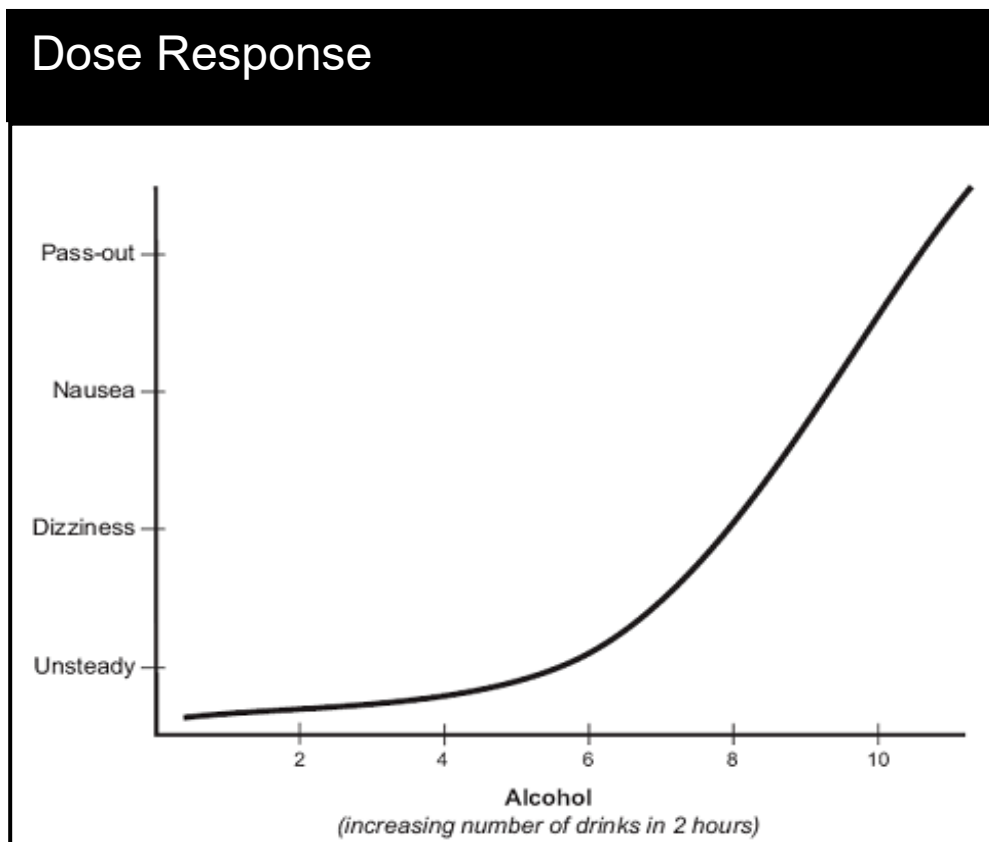

**Importance:** As the intake increases, there is more in the body (the dose increases) and the effect also increases.

Different individuals have different responses to an ammonia exposure. There are several factors that may influence response. These include current health status, age, race, sex, allergy history, genetics (heredity) and previous chemical exposure.

### Human one-time experimental ammonia exposure-response toxicity data

Concentration	Duration	Effect
300-500 ppm	30-60 minutes	could be tolerated
500 ppm	30 minutes	change in breathing rate Moderate to severe irritation
2,500-6,000 ppm	30 minutes	dangerous to life
5,000-10,000 ppm		fatal

Source: NIOSH. <https://www.cdc.gov/niosh/idlh/7664417.html> (other human data). These concentrations are used in laboratory experimental work only, not applicable to workplaces.

### Exposure or Dose?

The concentration of a chemical in the air is Exposure. The concentration of the chemical or a metabolite in the body is Dose.

## Effects of Chemicals on the Body - Local and Systemic Effects and Target Organs

---

Chemicals can have health effects at the point where they contact the body, or they may travel through the bloodstream and have effects on other areas of the body.

**Local effects** occur at the point of contact with the skin, eyes, nose, throat, and airways. Ammonia exposure can cause serious local effects.

**Systemic effects** occur away from where the exposure entered the body. Because ammonia is so reactive with water, effects are not systemic.

The part of the body which is specifically affected by the exposure is called the **target organ**. The target organs for ammonia are the respiratory tract, skin and eyes.

## Heat and Cold

---

### Heat

Wearing protective gear adds to the risk of heat stress. Increased temperature puts extra physical stress on the body. Long periods of exposure to heat may cause illness, particularly if a responder is not accustomed to working with a high heat load. Heat builds up inside protective clothing, so there is a risk of heat stress even if outside temperatures are moderate.

Regular monitoring, observation and other protective measures such as rest breaks and adequate fluids are vital to prevent heat stress. Individuals react to heat in different ways. Some factors which add to the risk of heat stress include lack of physical fitness, age, low fluid intake, alcohol or drug use, sunburn, diarrhea, and infection.

The following descriptions of heat-related responses are taken from [https://www.osha.gov/SLTC/heatstress/heat\\_illnesses.html](https://www.osha.gov/SLTC/heatstress/heat_illnesses.html).

#### Heat Rash or Prickly Heat

Symptoms: Little bumps that look like blisters on the skin surrounded by reddened skin

Cause: Increased sweating causes pores to be blocked causing irritation

Treatment: Remove or loosen clothing; topical creams may help relieve itching.

#### Heat Cramps

Symptoms: Painful muscle spasms

Cause: Profuse sweating and drinking large amounts of water

Treatment: Provide liquids with electrolytes (sodium, potassium) like diluted Gatorade™

#### Heat Exhaustion

Symptoms: Weakness; fatigue; dizziness; pale, cool, moist skin; heavy sweating; headache; nausea; and fainting

Cause: Reduced blood volume resulting from dehydration from profuse sweating and insufficient replacement of water and salts

Treatment: If worker is conscious, provide rest in a cool place. Replace water and electrolytes lost in sweat. If worker is unconscious, get medical help immediately. Do not give liquids if the person is unconscious.

### Heat Stroke

- Symptoms:** Very dry, hot skin with red, mottled or bluish appearance; confusion; convulsions; unconsciousness; rapidly rising temperature
- Cause:** Body becomes overheated because the worker does not sweat. Can be fatal.
- Treatment:** Call for medical help immediately. Move person to a cool place. Remove PPE. Use wet towels or water and fan to cool while waiting for help.

Heat stroke is a life-threatening emergency. Medical attention is required.

These are described on an OSHA QuickCard that you can print and keep with you. See <https://www.osha.gov/Publications/osha3154.pdf>

To monitor the risk of heat-related illness, OSHA has a smartphone app. See [https://www.osha.gov/SLTC/heatillness/heat\\_index/heat\\_app.html](https://www.osha.gov/SLTC/heatillness/heat_index/heat_app.html)

### Cold

Cold stress is less common than heat-related injury but may occur outdoors in winter months or during some ammonia responses. Liquid ammonia will 'take heat' away from the surrounding area as it changes to the gaseous form during a release. This results in cooling of the surrounding area, and if the area is small, cold stress could be a concern. Moreover, an ammonia release could be an area already purposefully cooled as part of the process.

Information on response to cold is shown below:

#### Frostbite

- Symptoms:** Numbness of hands, feet, or face.
- Cause:** Prolonged exposure to cold environments.
- Treatment:** Frostbitten tissue should be gently warmed and not exposed to further cold.

#### Hypothermia

- Symptoms:** Lowered body temperature, shivering, or drowsiness. If body temperature is reduced to 80°F (or below), unconsciousness is often followed by death.
- Cause:** Wet, cold, exhaustion; body's response to minimize heat loss becomes ineffective when body temperature goes below 86°F
- Treatment:** Warm the body. Get medical assistance.

See <https://www.osha.gov/SLTC/emergencypreparedness/guides/cold.html>

**Medical Surveillance Program**

Medical surveillance is a required consideration for emergency response (OSHA 29 CFR 1910.120[f]). It is essential to assess and monitor responders' health and fitness both prior to and during employment, provide emergency and other treatment as needed, and retain accurate records for future reference. A medical surveillance program should be instituted by the employer for the following employees:

- All employees who are or may be exposed to hazardous substances or health hazards at or above the PEL or above another published exposure level (if no PEL) for 30 days or more a year
- All employees who wear a respirator for 30 days or more a year
- All employees who are injured due to overexposure from an emergency incident involving hazardous substances or health hazards
- Members of official hazardous materials response teams
- Hazard materials specialists

In accordance with the standard, medical examinations and consultations are made available by the employer to each employee who falls into one or more of the above categories.

Medical exams should be conducted:

- Prior to a new job assignment (pre-placement or reassessment exam)
- At least once every year but not less often than every two years
- At termination
- If an employee exhibits signs or symptoms which may have resulted from exposure to hazardous substances during an emergency incident, or if the employee has been injured or exposed above the PEL or published exposure levels in an emergency
- More than once each year, if the physician determines that an increased frequency of examination is medically necessary

All medical examinations and procedures must be performed by or under the supervision of a licensed physician, preferably one knowledgeable in occupational medicine. The exam is provided without cost to the employee, without loss of pay, and at a reasonable time and place.

The content of the examination or consultations made will be determined by the physician. The physician may not understand the details of the employee's work. Therefore, before the examination it is important to explain to the physician the type of

work, potential health risks, and the type of protective equipment which may be worn for the response. Materials provided may include but may not be limited to:

- Copy of 29 CFR 1910.120 (HAZWOPER)
- Information required by 29 CFR 1910.134 (Respiratory protection)

The employer should then obtain the following items from the attending physician and furnish the information to the employee:

- The physician's opinion relative to the individual's employment or job assignment (Findings not relevant to the response duties are not to be given to the employer)
- The physician's recommended limitations to the employee's assigned response role
- The results of the medical examination and tests if requested by the employee
- A statement that the employee has been informed by the physician of the examination results and any conditions which require further examination or treatment (employer receives only work-related information)

Employees have a right to request and be given a copy of the physician's full report. The report should be kept in a safe place and/or forwarded to your family physician.

The employer must keep records of medical exams and other exposure records for the duration of an individual's employment plus 30 years thereafter. The record should include at least the following items:

- Name and social security number and employee physician's report
- Employee reports of health effects related to exposure
- Copy of information provided to the physician by the employer, except for 29 CFR 1910.120

### **Exposure Records**

Results of any exposure monitoring conducted by your employer relevant to your work activities are considered part of your medical record and must be available to you upon request.

See the OSHA "Access to Employee Exposure and Medical Records" (29 CFR 1910.1020). Records that workers can request include either environmental information (including monitoring results, Safety Data Sheets, lists of chemical or physical agents related to the job, studies/analyses of data) or personal medical records. When requested, the employer must provide access within fifteen working days after the request is made. The employer can comply by either making a copy of the requested

records at no cost to the employee or allowing the employee to use the employer copy machine to copy the records.

Things the Responder Should Do:

- Report all work-related injuries or illnesses immediately to the company physician and/or a personal doctor.
- Request and keep full copies of medical records.
- Examine and keep copies of exposure records.
- Actively participate in training on the potential health effects of all chemicals that you may encounter.
- Ask questions of health and safety representatives.
- See an occupational physician, if a second opinion is wanted.

### **Summary – Toxicology and Health Effects**

---

- An acute effect results from a high concentration of a toxic chemical once or for a short period of time; the chemical causes acute toxicity
- A chronic effect results from repeated exposure over a long period of time (generally years); the chemical causes chronic toxicity
- Local effects of a toxic chemical exposure occur at the point of contact with the body (skin, eyes, and lungs)
- Systemic effects occur when a toxic chemical enters the body through one or more routes of entry, but the effects are to tissues or organs away from the entry
- Routes of entry into the body are the skin, inhalation, injection, and ingestion; the most important routes of entry for ammonia are inhalation and skin/eye contact
- An organ of the body affected by a toxic chemical is called a target organ; target organs for ammonia toxicity are skin, eyes and respiratory tract
- Dose-response refers to the relationship between uptake of a chemical and a toxic response. As the dose increases, the health hazard to the worker increases. Exposure is measured outside the body; exposure-response is the relation between exposure and response.
- Heat and cold exposure can cause serious injury.
- Medical surveillance that must be conducted for emergency responders is shown in HAZWOPER. The employer must pay for required exams; all medical records (including relevant exposure records) must be retained by the employer for the

- duration of employment plus 30 years after each employee leaves employment.
- You have the right to obtain a copy of your work medical record at no cost to you. Retain the information with your personal medical records and share with your health care provider.



# **Personal Protective Equipment (PPE)**

---

## **Introduction**

---

The purpose of PPE is to shield or isolate responders from the chemical, physical, and biological hazards that may be encountered at a response.

Careful selection and use of adequate PPE should protect the respiratory system, skin, eyes, ears, face, hands, feet, and head. OSHA requires that the selected personal protective equipment must fit the responder who is utilizing it; this can be accomplished by having several sizes. For example, not everyone can wear the same size of gloves; different sizes of protective suits are needed for a person who is 6 feet tall and a person who is 5 feet tall, even if the waist sizes are the same.

In those cases where it is required, the employer must provide and pay for personal protective equipment. The exception is that the employer is not required to pay for PPE that can be used away from the worksite, such as prescription safety glasses and some safety shoes.

In this section, respiratory protection, chemical protective clothing and other PPE are covered. PPE is a critical component of protection for responders during an ammonia release response as other controls (process change, ventilation) may not be feasible.

## **Respiratory-Protective Equipment (RPE)**

---

Respiratory protection is required during emergency response activities, because adequate exposure control is rarely provided by use of engineering or administrative controls. This section outlines different types of respiratory-protective equipment (RPE), its use and limitations.

Respirators provide protection against chemical and dust exposure. Employers must provide responders with appropriate respirators and training if respirators are needed for usual or emergency work tasks. OSHA Standard 29 CFR 1910.134 requires that a written respiratory protection program be developed by the employer including use during an emergency.

### **Section Objectives**

---

When you have completed this section, you will be better able to:

- Describe appropriate applications of respiratory protection for ammonia response
- Evaluate situations to determine if respiratory protection is required
- Identify the requirements of a respiratory protection program
- Demonstrate ability to don, use (inspect and clean) and doff respirators
- Identify the elements of respirator training that should be provided by the employer

### Respirator Selection

---

Different hazards require different types of respirators. Several factors should be considered when selecting a respirator. Selecting the appropriate respirator is the responsibility of qualified personnel, such as an industrial hygienist.

Some considerations used to select a respirator include:

- What is the oxygen content of the atmosphere?
- What are the hazardous substances to which the responder may be exposed?
- Is the atmosphere immediately dangerous to life and health (IDLH)?
- What is the concentration of the substance in the air?
- What is the Permissible Exposure Limit (PEL) or Short-term Exposure Limit (STEL) for the substance?
- Is the respirator approved for the application?

Other selection considerations include:

- Communication needs
- Use in confined space
- Use in extreme temperatures
- Skin and eye absorption hazards
- Maximum use concentrations (MUC)
- Face protection
- Manufacturer limitations and cautions

### Types of Respirators

---

Two basic types of respiratory protection are:

**Air-Purifying Respirator (APR)** protects against toxic dusts, gases, and vapors by removing the contaminant from the air before it enters the lungs. APRs include negative pressure and Powered Air-Purifying Respirators (PAPR).

**Atmosphere-Supplying Respirator (ASR)** provides breathing air from a source independent of the ambient atmosphere. ASRs include supplied-air respirators (SAR) and self-contained breathing apparatus (SCBA).

## **Air-Purifying Respirators**

**Air-Purifying Respirators (APRs)** are used to protect against specific dusts and toxic chemicals. They work by removing the contaminant by filtering, adsorbing, or reacting with the airborne contaminant air before it is inhaled.

If APRs are used:

- all toxic substances must be identified
- the concentration must be known throughout the response by monitoring
- the respirator and cartridge must be selected to protect against those specific chemicals
- the oxygen concentration must be 19.5% or greater
- APRs are not used in atmospheres Immediately Dangerous to Life and Health (IDLH)

APRs can be reusable or single use. Reusable APRs consist of a facepiece with an exhalation valve and one or two filtering cartridges through which the air enters. The most widely used facepieces are full-face or half-mask. Full-face and half-mask respirators are illustrated below. Only full-face are used for ammonia responses.

**APRs cannot be used in an IDLH atmosphere  
Half-mask is NOT used with Ammonia Exposure**



Full-face Air-Purifying Respirator

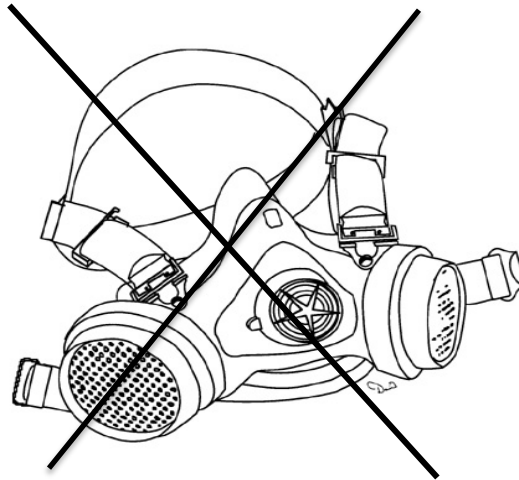

Half- mask Air-Purifying Respirator

## PPE - Respiratory-Protective Equipment

A Powered Air Purifying Respirator (PAPR) operates by forcing filtered (cleaned) air into the facepiece. The filters are away from the facepiece, nearer the power pack that moves the air. PAPRs are not used in flammable or explosive atmospheres. For ammonia responses, only full-face PAPRs may be used.

Single-use APRs are typically filtering-facepiece respirators, often known as dust masks and are not used at ammonia responses.

### Cartridges and filters for protection from Chemicals and Particles

Two types of air-purifying elements are used with APRs:

- **Chemical cartridges** are used to protect against certain vapors and gases.
- **Particulate cartridge filters** are used to protect against dusts, mists, and fumes.

Cartridge colors designate the chemicals that are removed from the inhaled air. OSHA regulation 29 CFR 1910.134 dictates the colors that may be used. The table below lists OSHA-approved color and protection combinations. **Bolded** entries are appropriate for protection against ammonia exposures.

Contaminants to be Protected Against	Color Assigned <sup>1</sup>
Acid gases	White
Hydrocyanic acid gas	White with 1/2-inch green stripe completely around the canister near the bottom
Chlorine gas	White with 1/2-inch yellow stripe completely around the canister near the bottom
Organic vapors	Black
<b>Ammonia gas</b>	<b>Green</b>
<b>Acid gases and ammonia gas</b>	<b>Green with 1/2-inch white stripe completely around the canister near the bottom</b>
Carbon monoxide	Blue
Acid gases and organic vapors	Yellow
Hydrocyanic acid gas and chloropicrin vapor	Yellow with 1/2-inch blue stripe completely around the canister near the bottom
<b>Acid gases, organic vapors, and ammonia gases</b>	<b>Brown</b>
Radioactive materials, except tritium & noble gases	Purple (magenta)
Pesticides	Organic vapor canister & a particulate filter

## PPE - Respiratory-Protective Equipment

Multi-Contaminant and CBRN agent	Olive
Any particulates - P100	Purple
Any particulates - P95, P99, R95, R99, R100	Orange <sup>2</sup>
Any particulates free of oil - N95, N99, or N100	Teal

<sup>1</sup>Gray shall not be assigned as the main color for a canister designed to remove acids or vapors.

<sup>2</sup>Orange shall be used as a complete body or stripe color to represent gases not included in this table. The user will need to refer to the canister label to determine the degree of protection the canister will afford.

### Chemical Cartridges

How do you tell if the cartridge needs to be changed? The respirator standard, 29 CFR 1910.134(d)(3), requires that respirators used to prevent gas or vapor exposures be equipped with an indicator showing that the cartridge (certified by NIOSH for the contaminant) has expired; this is called an End-of-Service-Life Indicator (ESLI). It is rare to find an ESLI on a cartridge. If the cartridge approved for a specific gas/vapor exposure has no ESLI, then the employer must use objective data to determine a change schedule and describe it in the written respiratory protection program; expected concentration, humidity, temperature and work rate are important inputs to calculation of a breakthrough time. Should you detect the contaminant during a response, notify the safety officer or other designated response personnel immediately for instructions.

The person responsible for establishing a change-out schedule for chemical cartridges shall consider temperature, humidity, contaminate concentration, and work rate. At high concentrations such as during a response, the change-out schedule may be so frequent as to make the use of air-purifying respirators impractical.

## Atmosphere-Supplying Respirators (ASR)

---

### Supplied-Air Respirators (SAR)

A supplied-air respirator (SAR) provides at a minimum Grade D breathing air to the worker from a stationary tank or other source through an air lines that cannot exceed 300 feet in length. When using an SAR, the worker must wear (not carry) an escape bottle containing a minimum of 5 minutes of air. This escape bottle, or egress unit, is required to allow the worker time to escape if the air supply is interrupted.

There are three classifications of supplied air respirators:

- Hose mask with blower (Type A)
- Hose mask without blower (Type B)
- Airline respirators (Type C)

Types A and B do not meet the requirements for emergency response and cannot be used; therefore, these units are not covered in this training.

Airline respirators must operate in either **continuous-flow** or **pressure-demand** mode. In continuous-flow mode, air is always flowing, even when the wearer is not inhaling. In pressure-demand mode, a constant positive pressure is maintained inside the facepiece; air flows when the positive pressure in the facepiece is reduced as the wearer inhales. A third mode of operation is **demand mode**, in which air only flows when the pressure inside the facepiece becomes negative due to the wearer inhaling. Demand mode provides the least protection, because contaminants can leak into a poorly sealed facepiece when the pressure becomes negative. NOTE: Not allowed when the concentration is unknown or IDLH conditions.

Compressors used to supply air must meet special requirements. Compressor exhaust and lubricants must not contaminate the air supplied. Compressor air intakes must be in a contaminant-free area.

### Self-Contained Breathing Apparatus (SCBA)

A self-contained breathing apparatus is an atmosphere-supplying respirator where the breathing air is carried by the user. An SCBA is used when extremely toxic chemicals are present, in an oxygen-deficient atmosphere, or when the contaminant or concentration is not known.

SCBAs consist of:

- **Bottle (tank or cylinder)** contains compressed breathing air (2216 psi-5500 psi)
- **Harness** secures cylinder and connects user to apparatus
- **Gauge** displays current cylinder pressure
- **Safety/by-pass valve** by-passes the regulator in case of malfunction of the regulator. The by-pass valve should be open only when needed
- **Pressure regulator(s)** provide reduced pressure air during inhalation
- **Full facepiece** isolates user's face (eyes, nose, mouth) from exterior environment

The SCBA is equipped with an alarm to warn the wearer when air in the tank falls below a specified capacity (note that the 2013 edition of NFPA 1981 specifies a 33% capacity alarm; NIOSH specifies 25%). Most SCBAs operate in an open-circuit mode; that is, the

exhaled air is vented to the atmosphere and not re-breathed.

SCBAs and cylinders differ by manufacturer and type. You must be trained in the manufacturer's instructions and checkout procedures before using any SCBA. These units should be NIOSH certified for IDLH and have a full facepiece for use in ammonia atmospheres; the air cylinder should provide a minimum duration of 30 minutes. An SCBA can operate in either demand mode (less protective) or pressure-demand mode. SCBA cylinders may be constructed of steel, aluminum, or composite materials. These have varying service lives and hydrostatic testing requirements. Users should familiarize themselves with their specific cylinders. A positive-pressure SCBA or positive-pressure airline respirator equipped with an escape air supply must be used when exposure levels are likely to present an IDLH situation or impair the ability to escape.

The equipment should be donned according to the manufacturer's recommended procedures. Periodic training and practice are especially important for workers who may use this equipment infrequently.



# PPE - Respiratory-Protective Equipment

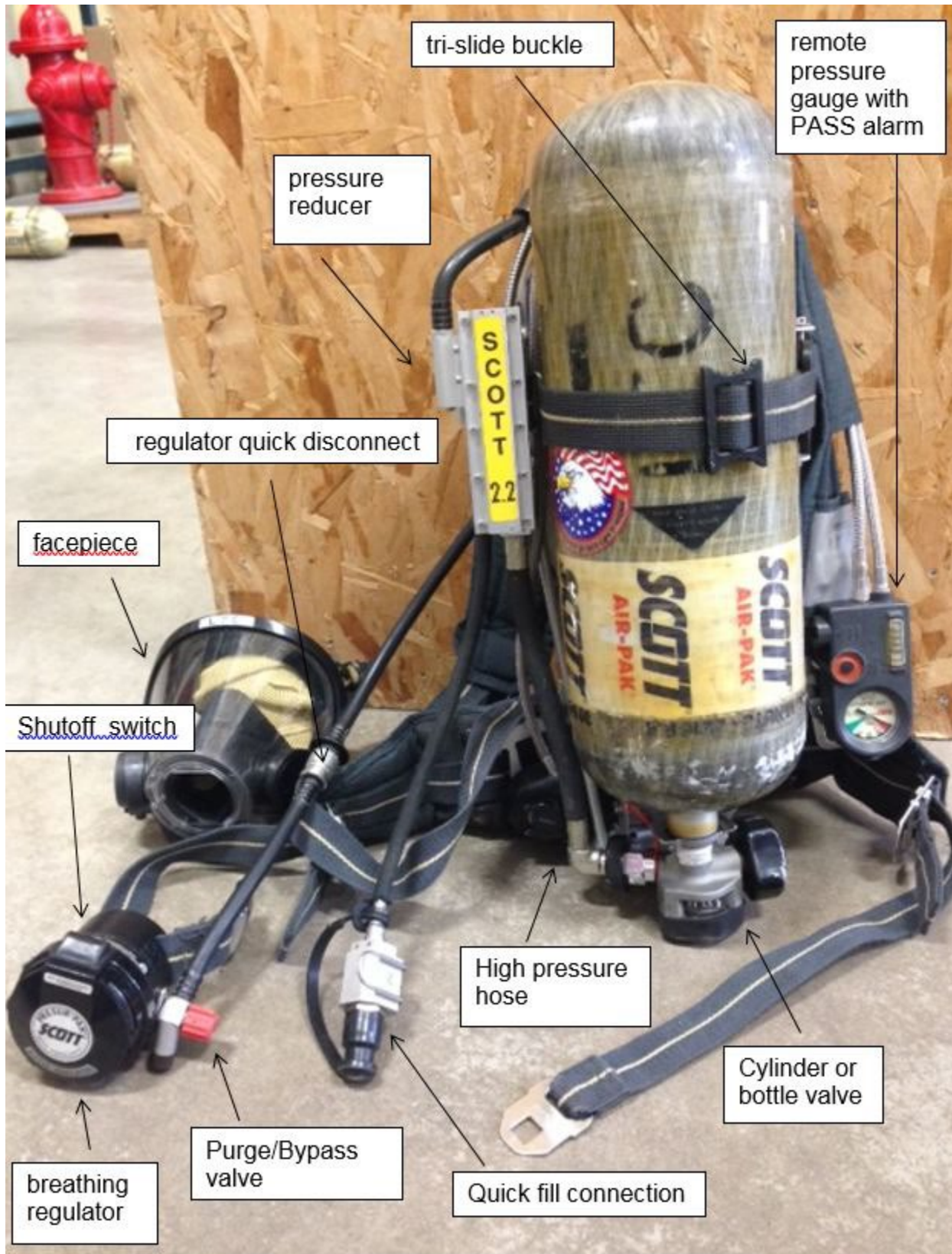

## **Occupational Exposure Limits and Guidelines**

---

Workplace exposures to chemicals are expressed as a concentration, or the amount of a substance contained in a known volume of air.

Concentrations of gases or vapors such as ammonia at a response are usually measured in parts per million (ppm), or milligrams per cubic meter (mg/m<sup>3</sup>).

- 1 ppm is a drop of water in 13.2 gallons of water or about 4 drops in a 55-gallon drum
- There are about 400,000 milligrams in one pound
- There are about 35 cubic feet in one cubic meter. (A meter is about 40 inches)

Percent by volume of air (%) is used for higher concentrations such as explosive limits; a concentration of 1% is 10,000 ppm.

### **Sources of limits and guidelines**

OSHA sets and enforces airborne exposure limits. Generally, the enforced level is the Permissible Exposure Limit (PEL); however, OSHA inspectors can build a case to cite based on an exposure guideline if the PEL is considered 'old and outdated' or there is no PEL.

NIOSH and non-governmental agencies (such as ACGIH®) have also established exposure levels to protect health. These guidelines and recommendations are not legally enforceable. Some exposure levels have a "skin" designation to indicate that the material is readily absorbed through the skin.

All these organizations provide background on how the number was determined; however, it is notable that the numbers are often quite different. The process to set a standard through OSHA takes many years, and therefore most OSHA standards have not been changed since the agency was established in 1970. ACGIH® and NIOSH update values more often. All groups consider the need to limit exposure to preserve health when a new number is developed.

Some large companies provide Occupational Exposure Levels (OELs) that could be different and are generally lower than the PEL. Exposure standards as used in this training are enforceable by a government agency. You may see other sources of standards; for example, the American National Standards Institute (ANSI) develops consensus documents referred to as standards, but that are not enforced by ANSI.

Below are several terms used to describe exposure levels. As appropriate the group providing the value is shown.

### **Immediately Dangerous to Life and Health (IDLH)**

IDLH is a concentration or condition that poses an immediate threat to life or health or might prevent someone from escaping such an environment. IDLH conditions include atmospheres where a chemical is present above the IDLH concentration, when the oxygen concentration in the air is too low, or when there is risk of explosion.

IDLH for ammonia is 300 ppm

### **Permissible Exposure Limits (PELs)**

Permissible exposure limits (PELs) are legally enforced exposure concentrations set by OSHA. Employers are required by law to not exceed the PELs using the hierarchy of controls to achieve compliance. In most cases, the PELs have not been updated for many years.

PEL for ammonia is 50 ppm (averaged over 8 hours)

### **Threshold Limit Values (TLVs)**

Threshold limit values (TLVs) are exposure levels prepared by the ACGIH®, a private, non-governmental agency. TLVs are not legally enforceable but do include updates of some values each year. They are usually more protective (lower) than PELs. TLVs are not listed in the NIOSH Pocket Guide, and the full listing and basis for the concentration are only available for a fee. The TLV is listed in safety information from chemical suppliers.

TLV for ammonia is 25 ppm (averaged over an 8-hour work shift)

### **Recommended Exposure Limits (RELs)**

Recommended exposure limits (RELs) are set by NIOSH. RELs are not legally enforceable. Like TLVs, RELs are generally more protective than the legally enforced PELs. RELs are shown in the NIOSH Pocket Guide (NPG), accessed at <https://www.cdc.gov/niosh/npg/>.

REL for ammonia is 25 ppm (averaged over a work shift of up to 10 hours)

### **Short-Term Exposure Limits (STELs)**

These exposure levels are set by ACGIH®, OSHA, and NIOSH. The **STEL** is a maximum average concentration a person may be exposed to over a short period of time, usually 15 minutes. It is legally enforceable if set by OSHA. STEL is sometimes abbreviated further to ST.

OSHA has set no STEL for ammonia

ACGIH STEL for ammonia is 35 ppm

NIOSH STEL for ammonia is 35 ppm

### Ceiling Limits (C)

The **ceiling** (C) is an exposure level set by ACGIH®, OSHA, and NIOSH which should not be exceeded at any time. It is legally enforceable if set by OSHA.

No C values have been set for ammonia

### Time-Weighted Averages (TWAs)

Most PELs and TLVs are 8-hour time-weighted average concentrations in a 40-hour work week. The NIOSH REL is for up to a 10-hour day while limiting the work week to 40 hours. This averaging is consistent with an assumption that there is time away from exposure during which the chemical is metabolized or cleared from the body.

An example of how the TWA is calculated follows:

#### Time-Weighted Averages Calculated

An employee is exposed to ammonia at 40 ppm for 6 hours and 12 ppm for 2 hours while conducting monitoring during response to a major release. What is the TWA?

$$\text{TWA} = \frac{(\text{Exposure}_1 \times \text{Time}_1) + (\text{Exposure}_2 \times \text{Time}_2) + \dots}{(\text{Time}_1 + \text{Time}_2 + \dots)}$$

$$\text{TWA} = \frac{(40 \text{ ppm} \times 6 \text{ hrs}) + (12 \text{ ppm} \times 2 \text{ hrs})}{(6 \text{ hrs} + 2 \text{ hrs})}$$

$$\text{TWA} = \frac{(240 + 24) \text{ ppm hrs}}{8 \text{ hrs}}$$

$$\text{TWA} = 33 \text{ ppm}$$

Compare this result with the current OSHA PEL for ammonia of 50 ppm.

- Has the PEL been exceeded?
- Were any exposure guidelines exceeded for any portion of the time sampled?

### Exposure Records

Reminder: Results of any relevant exposure monitoring conducted by your employer are considered part of your medical record and must be made available to you upon

request. See the OSHA Standard “Access to Employee Exposure and Medical Records” (29 CFR 1910.1020).

### Respirator Fit

---

A respirator is effective only if there is a good seal between the facepiece and the wearer’s face. Therefore, all persons wearing respirators must first be fit tested. Fit testing includes qualitative or quantitative testing, as well as routine positive- and negative-pressure user checks.

Because human faces come in many different shapes and sizes, each manufacturer has several facepiece sizes. The purpose of fit testing is to find the manufacturer/size combination which offers adequate protection. Factors such as weight loss or gain, dentures, dental work, or facial injury can change the shape of the face, thus potentially changing the fit and efficiency of the respirator. When any of these factors or others are identified that may affect fit, retesting is required.

#### Annual Fit tests

Two types of fit testing, **qualitative** and **quantitative**, may be used to determine the size and model of respirator that an individual should wear as well as how good the face-to-facepiece seal is. These tests must be repeated annually to document respirator effectiveness. Fit tests **shall not** be performed if facial hair is present in the seal area of the respirator. (OSHA 29 CFR 1910.134)

#### Qualitative Testing

**Purpose:** Checks effectiveness of preventing substances from entering the facepiece.

**Method:** While the individual is wearing a respirator, a test substance is released, as shown on the right. The test substance could be smelly (banana oil), sweet (saccharin), bitter (Bitrex) or an irritant (special smoke tube). The wearer should not be able to detect the substance while performing a series of prescribed tasks.

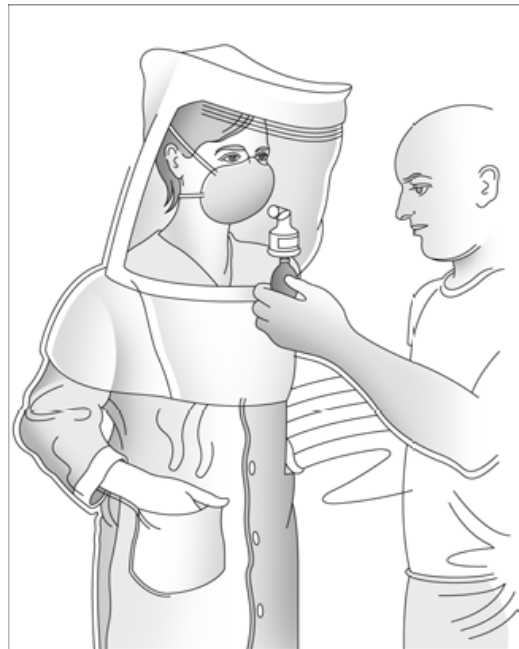

**Requirements:** This test or its equivalent is required by OSHA at least once a year.

There are several important cautions to qualitative fit testing:

- Some of the test substances may irritate the eyes or cause coughing
- A sensitivity test is first performed to determine if the individual is capable of sensing the test solution
- Fit testing is often done in “ideal” environments. The fit may change after wearing the respirator several hours or during strenuous activity.
- Must be used only when the required ratio of the concentration outside to the concentration inside the facepiece is less than or equal to 100; this is called the Fit Factor (FF)
- Generally not appropriate for emergency response use

### **Quantitative (Numerical) Testing**

This test measures the fit factor (FF), a comparison of the concentration of a substance outside of the mask to the concentration of a substance inside of the mask. The FF is useful in determining whether the respirator will effectively protect the wearer from exposure.

**Purpose:** Measures effectiveness of the respirator in preventing a substance from entering the facepiece.

**Methods:** There are two methods for quantitative fit testing based on the fit testing device.

1. While an individual wears a respirator modified with a probe, the concentrations of particulates in the air inside and outside of the respirator are measured, as shown above. The test is repeated while the person performs specific tasks (speaking, running in place, etc.) that may affect fit.
2. While an individual wears a respirator connected to a fit testing device, a vacuum is drawn in the mask to assess the seal for leaks. Then the user removes and re-dons the mask and the test is repeated twice.

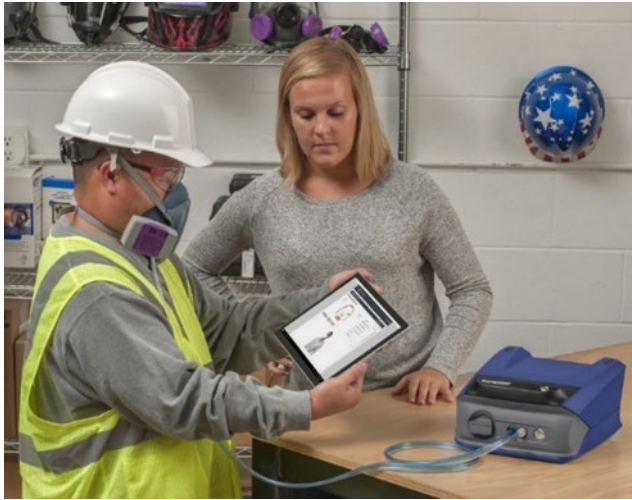

Photo courtesy of TSI Inc. to MWC

**Requirement:** This test is mandated when a fit factor of 500 is required.

### **Routine User Checks**

Both **positive-** and **negative-**pressure user checks are done each time a respirator is donned to check the seal. They do not replace yearly fit testing but provide a routine assessment as to whether the fit is still adequate.

### **Positive-Pressure User Check**

**Purpose:** Checks the facepiece components for leaks at valves or other points.

**NOTE:** Not all respirators allow easy access to the exhalation valve for this test.

**Method:** Close off the exhalation valve (if possible) and exhale gently into the facepiece. The face fit is considered satisfactory if a slight positive pressure can be built up inside the facepiece without any evidence of outward leakage of air at the seal. For most respirators this method of leak testing requires the wearer to first remove the exhalation valve cover before closing off the exhalation valve and then carefully replacing it after the test. This is only performed if the cover can be manually removed.

**Requirement:** Shall be done before each use.

### Negative-Pressure User Check

**Purpose:** Checks the facepiece-to-face seal.

**Method:** SCBA wearer disconnects the regulator and places hands over the hole for the regulator connection and inhales. APR wearer places hands over cartridges and inhales, as shown on the right. No outside air should be felt leaking into the facepiece.

**Requirement:** Shall be done each time the respirator is donned (first use, breaks, lunch).

Positive- and negative-pressure checks can be done quickly and easily in the field. If the wearer is unable to block the holes or cartridges with their hands, additional measures may be needed to accomplish the blocking requirement to detect the leaks.

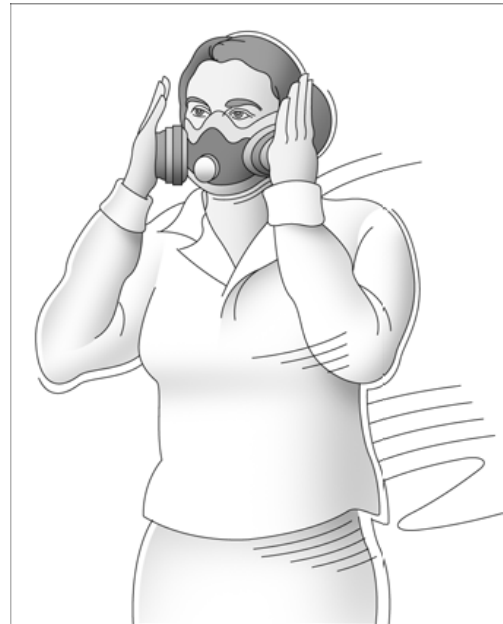

### Assigned Protection Factors

Respirators are initially selected by using Assigned Protection Factors (APFs). A protection factor has been determined in the laboratory at NIOSH for each type of respirator (APR, PAPR, SCBA, etc.) and mask (half- or full-face). Protection factors also exist for combinations of respirators. For example, an SAR with a full-face mask and an auxiliary SCBA equals 10,000. The higher the APF, the more protective the respirator is likely to be, but fit testing must be performed.



## PPE - Respiratory-Protective Equipment

The following table shows APFs for respirators that may be used to protect against ammonia:

Assigned Protection Factors (APFs)					
Type of Respirator	Quarter mask*	Half mask	Full facepiece	Helmet/Hood	Loose-fitting facepiece
1. Air-purifying Respirator	5	10*	50	-	-
2. Powered Air-purifying Respirator (PAPR)	-	50*	1,000	25/1,000*	25
3. Supplied-air Respirator (SAR) or Airline Respirator					
• Demand mode	-	10	50	-	-
• Continuous flow mode	-	50	1,000	25/1,000	25
• Pressure-demand or other positive-pressure mode	-	50	1,000	-	-
4. Self-contained Breathing Apparatus (SCBA)					
• Demand mode	-	10	50	50	-
• Pressure-demand or other positive-pressure mode (e.g., open/closed circuit)	-	-	10,000	10,000	-

\*Not appropriate for ammonia exposures.

Never assume you will get this much protection. Quantitative fit testing provides a measure of the maximum protection you can expect. Less protection may occur during response activities.

### Fit Factor Calculation

Selection of respirators includes calculation of the fit factor by dividing the known or expected chemical concentration by the APF. The resulting value is compared with the occupational exposure guideline used by your employer.

$$\frac{\text{measured chemical concentration (ppm)}}{APF} = \text{parts per million (ppm)}$$

If the calculated ppm is higher than the exposure guideline, then that type of respiratory protection would be inadequate. If the calculated ppm is lower than the exposure guideline, then that type of respiratory protection should be protective, provided that the measured concentration will not increase, and that the measured concentration is below the IDLH concentration, if using an APR.

### Sample Fit Factor Calculation (and a double check on protection):

Ammonia released from a faulty valve has resulted in a loss of an unknown amount. The first entry team wore SCBAs and stopped the release. The safety and health officer monitored the concentration and found 400 ppm at the entrance. This is not a TWA, but a single measurement on a direct-reading instrument. The OSHA PEL is 50 ppm for an 8-hour work shift; it is expected that the response by the responders will take two hours. Because engineering controls cannot be implemented, respiratory protection must continue to be used. What type of respiratory protection would provide adequate protection against this contaminant?

Formula:  $\frac{\text{measured chemical concentration (ppm)}}{APF} = \text{ppm}$

First, use the table of APFs to see if a half-face APR can be used:

$$\frac{400 \text{ ppm}}{50} = 8 \text{ ppm}$$

The resulting answer is 8 ppm, which means that 8 ppm of ammonia could be present inside the facepiece of a properly fitted respirator. Even though the concentration is less than the OSHA 50 ppm PEL, this type of respiratory protection is NOT adequate.

Hint: IDLH = 300 ppm

**APRs cannot be used in an IDLH atmosphere**

Hint: eye irritant

**Half-face APRs cannot be used if eye hazard**

Full facepiece, supplied air is required.

## **Cleaning, Storage, Inspection and Maintenance of Respirators**

---

Proper cleaning, storage, inspection and maintenance are essential to ensure that the respirator is always ready for use. The OSHA respirator standard requires employers to provide for the cleaning and disinfection, storage, inspection and repair of respirators used by employees. Always follow manufacturers' recommendations for use, care and maintenance as well.

### **Cleaning respirators**

Appendix B-2 to 29 CFR 1910.134 requires the following respirator cleaning procedures. Manufacturers' recommendations may be used as an alternative, if they are at least as effective as those specified here from OSHA:

- A. Remove filters, cartridges, or canisters. Disassemble facepieces by removing speaking diaphragms, demand and pressure- demand valve assemblies, hoses, or any components recommended by the manufacturer. Discard or repair any defective parts.
- B. Wash components in warm (43 deg. C [110 deg. F] maximum) water with a mild detergent or with a cleaner recommended by the manufacturer. A stiff bristle (not wire) brush may be used to facilitate the removal of dirt.
- C. Rinse components thoroughly in clean, warm (43 deg. C [110 deg. F] maximum), preferably running water. Drain.
- D. When the cleaner used does not contain a disinfecting agent, respirator components should be immersed for two minutes in one of the following:
  1. Hypochlorite solution (50 ppm of chlorine) made by adding approximately one milliliter (approximately 20 drops) of laundry bleach to one liter of water (about a 1000:1 dilution) at 43 deg. C (110 deg. F); or,
  2. Aqueous solution of iodine (50 ppm iodine) made by adding approximately 0.8 milliliters (about 16 drops) of tincture of iodine (6-8 grams ammonium and/or potassium iodide/100 cc of 45% alcohol) to one liter of water (about a 1250:1 dilution) at 43 deg. C (110 deg. F); or,
  3. Other commercially available cleansers of equivalent disinfectant quality when used as directed, if their use is recommended or approved by the respirator manufacturer.
- E. Rinse components thoroughly in clean, warm (43 deg. C [110 deg. F] maximum), preferably running water. Drain. The importance of thorough rinsing cannot be overemphasized. Detergents or disinfectants that dry on facepieces may result in dermatitis. In addition, some disinfectants may cause deterioration of rubber or corrosion of metal parts if not completely removed.
- F. Components should be hand-dried with a clean lint-free cloth or air-dried.

- G. Reassemble facepiece, replacing filters, cartridges, and canisters where necessary.
- H. Test the respirator to ensure that all components work properly.

Respirators must be cleaned and disinfected after each use, unless they are being used routinely and exclusively by the same employee. In that case, they must be cleaned and disinfected as often as needed to be sanitary.

### **Respirator Storage**

OSHA requires that all respirators be stored to protect them from damage, contamination, dust, sunlight, extreme temperatures, excessive moisture, and damaging chemicals, and that they must be packed or stored to prevent deformation of the facepiece and exhalation valve.

### **Inspection**

Respirators must be inspected before and after each use and checked at least monthly, even if the respirator has not been used. A company policy may include more frequent inspections. OSHA requires that inspections include:

- A check of respirator function
- Tightness of connections
- The condition of the various parts including, but not limited to, the facepiece, head straps, valves, connecting tube, and cartridges, and canisters or filters
- A check of elastomeric parts for pliability and signs of deterioration.
- In addition to the above, self-contained breathing apparatus must be inspected monthly

Air cylinders must be maintained in a fully charged state and be recharged when the pressure falls to 90% of the manufacturer's recommended pressure level. The employer must determine that the regulator and warning devices function properly. NOTE: Cold temperatures may result in a pressure reading below 90%, even if the cylinder is full.

### **Maintenance**

OSHA requires that defective respirators be removed immediately from service and repaired/adjusted or discarded.

Repair program guidance follows:

- Repairs or adjustments must be made only by trained persons using the manufacturer's NIOSH-approved parts.

- Repairs must be made according to the manufacturer's recommendations and specifications.
- Critical parts including reducing and admission valves, regulators and alarms may only be adjusted or repaired by the manufacturer or a technician trained by the manufacturer.

Consult the site-specific respiratory protection program for detailed requirements. Know who takes reports for needed repair and assures repair or replacement occurs.

### **Minimum Requirements for a Respiratory Protection Program**

---

OSHA requires that employers who make respirators available to employees have a written respiratory protection program with work-specific procedures. The program must be evaluated and updated as necessary, due to changes in respiratory protection use, response procedures or feedback from users. OSHA requires the use of NIOSH-approved respirators. Approval numbers will be clearly written on all approved equipment. Respirators manufactured after 2008 are marked with an approval designation known as a "TC" number. [Example: TC #XXX-XXXX].

A respiratory protection program must include the following points:

- Medical evaluations of employees required to use respirators
- Fit testing procedures for tight-fitting respirators
- Procedures for proper use of respirators in routine and reasonably foreseeable emergency situations
- Procedures and schedules for cleaning, disinfecting, storing, inspecting, repairing, discarding, and otherwise maintaining respirators
- Procedures to ensure adequate air quality, quantity, and flow of breathing air for atmosphere-supplying respirators
- Training of responders in the respiratory hazards to which they may be potentially exposed during routine and emergency situations
- Training of responders in the proper use of respirators, including putting on and removing them, any limitations on their use, and their maintenance
- Procedures for regularly evaluating the effectiveness of the program

The employer must designate a program administrator who is qualified to oversee the respiratory protection program and to conduct the required evaluations of its effectiveness. Respirator training and the required medical evaluations are provided to the employee at no cost. The respiratory protection program also may include:

- Provision for corrective lenses in full facepiece respirators using a spectacle kit that clips into the facepiece or is permanently mounted in the facepiece
- Restriction of use of contact lenses. (See ANSI Z87.1)
- Communication needs
- Guidelines for use in dangerous atmospheres, including confined spaces
- Guidelines for use in extreme temperatures

The respiratory protection program will include a description of who is responsible for the various aspects of the program including selection, periodic and routine fit testing, inspection, cleaning, repair, and maintenance

Effective training must be provided at least annually by the employer for all employees who are required to use respirators (see 29 CFR 1910.134(k)). This training must be understandable to the participant. Based on the training, the employer shall ensure that each employee can demonstrate knowledge of at least the following:

- Why the respirator is necessary and how improper fit, usage, or maintenance can compromise the protective effect of the respirator
- Limitations and capabilities of the respirator
- How to use the respirator effectively in emergency situations, including situations in which the respirator malfunctions
- How to inspect, put on and remove, use, and check the seals of the respirator
- The procedures are for maintenance and storage of the respirator
- How to recognize medical signs and symptoms that may limit or prevent the effective use of respirators
- The general requirements of the respiratory protection standard

### **Medical Fitness to Wear a Respirator**

---

Before a responder receives clearance to wear a respirator, a medical evaluation must be performed by a physician or other licensed health care professional (PLHCP). The evaluation helps ensure that the employee is physically capable of working with the added stress of a respirator. Any follow-up evaluations and testing will be determined by the PLHCP.

Some medical conditions which may prevent respirator usage include:

- Lung disease
- Claustrophobia
- Severe high blood pressure
- Heart disease

Other conditions that should be considered when wearing a specific type of respirator include:

- Contact lenses
- Eyeglasses
- Moustache that may interfere with fit
- Perforated tympanic membrane (ruptured eardrum)

Changes in weight or dental work may alter the fit of a respirator and require a new fit test. Special eyeglass kits are available for use with full facepiece respirators.

### **Respiratory Protection Demo and Workshop**

---

In this Workshop, you will become familiar with APRs, SCBAs and egress units and equipment cleaning and inspection procedures. See Exercise Manual.

Demo: Don, doff full facepiece APR

Demo: Fit testing, qualitative and quantitative

Practice: User Checks of an APR

Practice: Donning and doffing full facepiece APR with supplied air bottle (SCBA)

Practice: Inspecting and cleaning respirators

Optional: Wearing an airline with escape unit

### **Summary – Respiratory-Protective Equipment**

---

Respiratory protection is required to prevent inhalation of ammonia during a response. The two basic types of respirators are air-purifying respirators (APRs) and atmosphere-supplying respirators (ASRs). Routine training and practice are necessary for use.

APRs used at a response consist of a facepiece with an exhalation valve and one or two filtering units through which the air enters. The cartridge filters for ammonia are banded with one of three colors: green, green/white, brown. APRs may not be used where the identity of the contaminant is unknown, oxygen concentration is less than 19.5% or in an IDLH atmosphere.

ASRs may be supplied-air respirators (SARs) or self-contained breathing apparatus (SCBAs). SCBAs consist of a facepiece, supply of air, gauge, and safety valve. If SARs are used, an escape unit must also be worn.

Situations that require the use of respiratory protection include:

- Oxygen deficiency
- Ammonia in the air during a response
- An atmosphere immediately dangerous to life and health (IDLH)

A respirator is assigned for use after either qualitative (the desired fit factor is  $\leq 100$ ) or quantitative fit testing. Before each use, the wearer conducts positive- and negative-pressure user checks.

Care of respirators includes diligent cleaning, disinfecting, storing and maintenance. Units should be inspected before and after each use or monthly if not used routinely. Names of personnel in charge of maintenance should be known to users to assure prompt reporting of defects for repair or replacement.

A respiratory protection program must include the following:

- Medical evaluations of employees required to use respirators
- Fit testing procedures for tight-fitting respirators
- Procedures for proper use of respirators in routine and reasonably foreseeable emergency situations
- Procedures and schedules for cleaning, disinfecting, storing, inspecting, repairing, discarding, and otherwise maintaining respirators
- Procedures to ensure adequate air quality, quantity, and flow of breathing air for atmosphere-supplying respirators
- Training of responders in the respiratory hazards to which they are potentially exposed during routine and emergency situations
- Training of responders in the proper use of respirators, including putting on and removing them, any limitations on their use, and their maintenance
- Procedures for regularly evaluating the effectiveness of the program

The employer must:

- Designate a program administrator who is qualified to oversee the respiratory protection program and conduct the required evaluations of its effectiveness
- Describe who is responsible for the various aspects of the program including selection, periodic and routine fit testing, inspection, cleaning, repair, and maintenance

At least annually, the employer must provide training in the use of assigned respiratory



## **PPE - Respiratory-Protective Equipment**

protection. Content must be understandable by participants and include at a minimum:

- Need for the protection
- How improper fit, use, storage and maintenance can limit protection
- Proper use, inspection, don/doff, user seal checks
- Maintenance and storage procedures
- Medical signs or symptoms that limit use
- General provisions of 29 CFR 1910.134

## **Chemical-Protective Clothing (CPC)**

---

Chemical-protective clothing (CPC) includes suits, aprons, gloves, safety goggles, and face shields. This provides an important barrier between chemicals or other hazards in the environment and your body. Although CPC and respirators cannot provide protection from all exposures, when properly selected and worn, the combination can limit harmful exposures. This section includes the use, selection and application of levels of protection as designated by EPA and OSHA. You will don and doff PPE.

### **Section Objectives**

---

When you have completed this section, you will be better able to:

- Identify general types and uses of RPE and CPC for ammonia environments
- Identify selection criteria for CPC for ammonia
- Describe precautions to be taken when wearing PPE
- Demonstrate proficiency donning and doffing PPE
- Identify proper procedures for inspection and storage of PPE and who to notify that maintenance is needed



Source:

[https://www.osha.gov/SLTC/etools/ammonia\\_refrigeration/emergency/index.html](https://www.osha.gov/SLTC/etools/ammonia_refrigeration/emergency/index.html)



Source: [https://www.epa.gov/sites/production/files/2015-05/documents/accident\\_prevention\\_ammonia\\_refrigeration\\_5-20-15.pdf](https://www.epa.gov/sites/production/files/2015-05/documents/accident_prevention_ammonia_refrigeration_5-20-15.pdf)

### **Chemical-Protective Clothing**

Chemical-Protective Clothing (CPC) consists of special clothing worn to prevent chemicals from contacting the body. CPC generally includes eye/face protection, aprons, boots, gloves, and suits/coveralls. CPC is used to protect responders from both chemical and physical hazards that they are likely to encounter. The proper use of CPC can prevent or reduce exposure to a harmful substance. CPC is an important part of an emergency responder's personal protective equipment (PPE).

The materials used to construct CPC are chemical-resistant, which means they act as a barrier to keep chemicals from contacting the wearer's skin. Different materials provide

protection from different types of chemicals. It is important to select CPC which is designed to protect against the specific chemical or type of chemical that may be encountered during an emergency response. Otherwise, you might not be protected, even when you think you are.

### **Personal Protective Equipment Program**

A written personal protective equipment program is required by OSHA as part of the employer's Emergency Response Plan. PPE must be selected to protect employees from known or likely potential hazards. The proper selection of PPE is based on many factors, including potential hazards, layout of the scene and surrounding activities.

#### **PPE must be properly selected and used to be effective.**

##### Examples of improper selection

- Goggles, when whole body splash is likely
- Gloves known to crack when wetted with ammonia

##### Examples of improper use

- Respirator 'stored' below the chin
- Continuing to work with a tear in CPC suit

What examples of improper selection or use have you seen?

The PPE program must address:

- Selection, based upon anticipated hazards (See 29 CFR 1910.132 Appendix B)
- Use and limitations
- Work task duration
- Maintenance and storage
- Decontamination and disposal
- Training and proper fitting
- Donning and doffing procedures prior to, during, and after use
- Inspection procedures
- Evaluation of program effectiveness
- Special limitations during temperature extremes, heat stress, and other appropriate medical considerations

When model procedure descriptions provided by the manufacturer will be followed exactly, they may be incorporated directly into the PPE Program.

Appropriate PPE must be purchased as part of preplanning, and it must be selected and

properly used during initial size-up and response activities. The size-up should provide enough information to select PPE to protect personnel from exposures to ammonia during a response. During size-up and other initial actions, responders may need a high level of protection. With the information gathered, including air monitoring, a decreased level of protection may be approved by the person in charge, following the ERP as response activities change. All PPE selected and used must meet OSHA requirements where applicable (29 CFR 1910, Subpart I and 29 CFR 1910.120).

## **Types of Chemical-Protective Suits**

---

Chemical-protective suits are of two general types: totally encapsulating and partially encapsulating.

**Totally Encapsulating Chemical-Protective Suit (TECP):** Provides head-to-toe coverage to protect the wearer from chemicals. These suits have special seams and zippers to prevent chemicals from leaking into the suit. These suits have a face shield which is made as part of the hood. They are very bulky to wear, and the wearer can become very hot while working. TECPs are the only vapor-resistant suits. TECP suits protect workers from hazards which are identified during initial hazards and risk assessment. TECP suits must pass specific positive-air pressure tests and be capable of preventing inward test gas leakage of more than 0.5%. Specific information about pressure tests can be found in OSHA 29 CFR 1910.120, Appendix A.

**Partially Encapsulating Chemical-Protective Suit (PECP):** Provides less protection from chemicals and may or may not have face shields. These suits are used when less skin protection is needed. The hood can either be part of the suit or detached. This type of CPC may include suits which look like totally encapsulating suits but will not pass a pressure test. A large variety of PECP designs is available.

Disposable suits that provide limited protection from chemicals can be used in conjunction with these chemical-protective suits. These disposable suits can be worn either on top of other suits to protect them or inside protective suits to protect the wearer from chafing, to limit contamination of personal clothing or to provide added protection during decon.

## **Selection of CPC**

---

PPE is effective only if it is properly selected, worn, and maintained. Standard Operating Procedures (SOPs) for PPE are included in the ERP. SOPs are employer-specific,

written instructions that are an administrative control. The more general Standard Operating Guides (SOGs) often used in training. Considerations include:

- Whenever possible, a variety of suit sizes should be on hand to fit the various sizes of personnel
- Adhesive on tape not approved by the manufacturer may cause degradation of the suit and the warranty may be voided
- Materials used to make most suits do not “breathe.” Rapid heat and moisture build-up will occur in the suit during use
- All suits have limits as to the temperature at which they can be worn without damage. This information may be particularly important for emergency response activities. Check the manufacturer’s data.
- Most suits offer no fire protection and, in some cases, increase the possibility of injury because they will melt and may burn

Generally, one person or the health and safety group is responsible for the selection and purchase of protective equipment; however, it is important for everyone to understand the considerations which go into the selection. The selection process should be detailed in the employer’s PPE plan. Questions about PPE selection should be addressed to the person responsible for the selection, before a response.

A hazard assessment with a survey of the facility is part of pre-emergency planning at fixed sites and will include a list of potential emergency releases or events. This list is used in planning for required PPE. In addition to ammonia, hazards to take into consideration include:

- Impact
- Compression, struck-by
- Heat/cold
- Lighting
- Sources of electricity
- High temperatures
- Fire
- Penetration/puncture hazards
- Combustible/Harmful dust
- Biologic agents due to worker injury
- Sources of motion or impact
- Other chemicals at the workplace

The type of chemical-protective suits selected will depend on the type and nature of potential exposure. For example, totally encapsulating suits may be required for persons approaching an ammonia release at a faulty valve; less protection is required for those involved in maintaining site security during the response. The level of protection provided will be re-evaluated as additional information is gained.

## **Ammonia-specific concerns for CPC Selection**

---

Emergency response to ammonia may involve exposure

- Liquid ammonia
- Ammonia gas/vapor
- Ammonium hydroxide

The CPC must be resistant to all three; otherwise the limitations of the CPC must be known and be consistent with the documented, more limited exposures.

Liquid ammonia boils at -28°F.

Escaping ammonia may create lower temperatures in the work area. Verify resistance/integrity of CPC at these lower temperatures.

Identify if CPC material has needed flexibility at low temperatures.

Some materials lose flexibility or integrity at low temperatures, making it difficult to do the work tasks or providing less protection.

Leave the area immediately if:

- Readings indicate that PPE is inadequate
- PPE failures occur

Guidelines for selection of PPE, including CPC suits, are presented in the following table.

## CPC Selection Guidelines

### Always follow manufacturer's recommendations

**Chemical resistance:** Different materials are resistant to different chemicals. Management should provide CPC which will provide protection against the chemicals likely to be encountered. This rule is true for whole-body as well as hand and foot protection.

**Physical integrity:** Construction of the suit is important for the proper functioning of the CPC. Seams and zippers should provide solid barriers to chemicals and should be constructed to prevent seam tears and rips during use

**Resistance to temperature extremes:** Heat and cold can adversely affect CPC. Clothing which will be worn in cold temperatures could crack or become ineffective against chemicals. Likewise, heat can destroy the chemical resistance of clothing or even melt it.

**Ability to be cleaned:** Clothing must be able to be cleaned and decontaminated after each use. If this is not possible, the clothing must be disposed of after use.

**Cost:** Initial and ongoing costs of purchasing PPE can be important considerations for management. However, buying less expensive, inferior products that do not adequately protect the wearer can be more expensive in the long run due to medical costs, lost work time, or, at worst, loss of human life.

**Flexibility:** Materials need to be flexible enough for the wearer to move and work safely. Overly rigid suits can result in unnecessary accidents from slips, trips, and falls. Gloves which are too rigid may create gripping problems that may lead to other hazards.

**Size:** CPC should be available in a variety of sizes to accommodate the height and weight of the worker. Suits that are too small will tear easily and provide no protection. Suits that are too large will make walking and/or working difficult. Safety boots that are too big will create both tripping and comfort problems.

**Design:** CPC should be designed so that all required respiratory PPE can be used at the same time. Some styles/designs require assistance to don/doff.



## **Levels of PPE (see 29 CFR 1910.120, Appendix B)**

---

### **Level A**

Level A is the highest level of protection which can be worn.

#### **What Is Level A Protection?**

The following list constitutes Level A equipment; it may be used as appropriate:

- Positive-pressure, pressure-demand, full facepiece SCBA or positive-pressure, supplied-air to full facepiece with escape SCBA (NIOSH-approved)
- Totally encapsulating chemical-protective suit (TECP) (gas tight or vapor tight)
- Inner and outer chemical-resistant gloves
- Disposable protective suit, gloves, and boots (depending on suit construction, may be worn over totally encapsulating suit)
- Coveralls\*
- Long underwear\*
- Hard hat (under suit)\*
- Chemical-resistant boots with steel toe and shank.
- Cooling system (ice vest, water/air circulation)\*

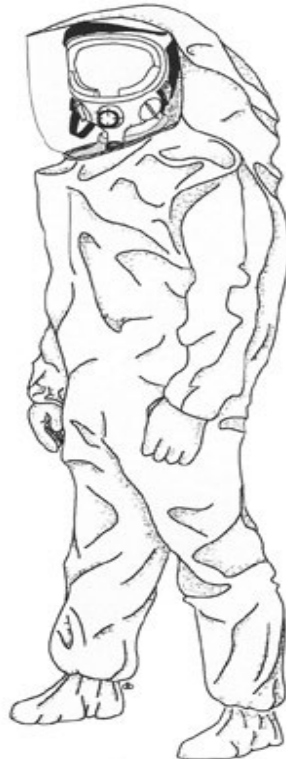

\*Optional as applicable

Note: Suit must be properly equipped with a pass-through airline connection, referred to as an airline egress if using an SAR.

Note: Know and follow manufacturer directions to remove fogging inside the suit.

#### **When Is Level A Protection Needed?**

Level A protection is required when:

- The hazardous substance has been identified and requires the highest level of protection for skin, eyes, and respiratory system.
- There is potential for splash, immersion, or exposure to vapors, particulates, or gases that are harmful to the skin or may be absorbed through the skin.
- Confined space entry may be involved and the need for Level A cannot be ruled out (but explosion hazard has been ruled out).
- The skin absorption hazard may likely result in immediate death or serious illness/injury or impair the ability to escape.

## **Level B**

Level B is used when maximum respiratory protection is desired, but the skin/eye hazards do not require Level A.

### **What Is Level B Protection?**

The following constitutes Level B equipment; it may be used as appropriate.

- Positive-pressure, full facepiece SCBA or positive-pressure, pressure-demand, supplied-air to full facepiece with escape SCBA (NIOSH approved)
- Hooded chemical-resistant clothing **OR** total encapsulating chemical suit (not gas tight or vapor tight)
- Inner and outer chemical-resistant gloves
- Outer chemical-resistant boots with steel toe and shank
- Boot covers: outer, chemical-resistant (disposable)\*
- Hard hat\*
- Face shield\*
- Cooling system (ice vest, water/air circulation)\*



New Level B chemical-resistant clothing is designed to go over the SCBA. If appropriate for the potential exposures, this CPC should be used to protect the SCBA and prevent its contamination. In this case, the Level B ensemble will resemble a Level A ensemble, but the suit is not vapor-tight.

\*Optional as applicable

### **When Is Level B Protection Needed?**

Level B protection is required when:

- The highest level of respiratory protection is needed but a lower level of skin protection (than Level A) is acceptable
- The substances have been identified
- A SCBA is required
- Less skin protection is needed. (Vapor and gases are not believed to be present at high levels harmful to skin or capable of being absorbed through intact skin)

## Level C

Level C provides less skin and respiratory protection than Level A or B.

### What Is Level C Protection?

The following list constitutes Level C equipment; it may be used as appropriate.

- A full-face air-purifying respirator (NIOSH-approved)
- Hooded chemical-resistant clothing
- Inner and outer chemical-resistant gloves
- Coveralls\*
- Boots (outer), chemical-resistant steel toe and shank\*
- Boot covers: outer, chemical-resistant (disposable)\*
- Hard hat\*
- Escape mask\*
- Face shield\*

\*Optional as applicable

### When Is Level C Protection Needed?

Level C provides protection when:

- The concentration(s) and type(s) of airborne substance(s) are known and the criteria for using an air-purifying respirator are met.
- Direct contact with the hazardous substance will not harm the skin or the substance will not be absorbed through any exposed skin.
- Air contaminants have been identified, concentrations measured, and an air-purifying respirator is available with an acceptable protection factor
- An adequate level of oxygen ( $\geq 19.5\%$ ) is available and all other criteria for the safe use of air-purifying respirators are met.



Note: In ammonia environments with levels below IDLH, CPC may not be needed depending on the task. For example, a responder tightening a packing on a dripping valve should use CPC and a face shield in case the packing breaks and ammonia sprays out. A responder observing the repair through a window may not require protective gear.

**Level D**

This level offers no respiratory protection and low skin protection.

**What Is Level D Protection?**

The following list constitutes Level D equipment; it may be used as appropriate.

- Coveralls (work uniform)
- Chemical-resistant boots or shoes with steel toe and shank
- Hard hat\*
- Gloves\*
- Outer, chemical-resistant boots (disposable)\*
- Safety glasses or chemical splash goggles\*
- Escape mask\*
- Face shield\*

\*Optional as applicable

**When Is Level D Protection Needed?**

Level D is required when:

- Minimal protection from chemical exposure is needed. It is worn to prevent nuisance contamination only
- The atmosphere contains no known hazards that require skin or respiratory protection
- Work functions preclude splashes, immersion, or the potential for unexpected inhalation of or contact with hazardous levels of any chemicals

**Typical Uses of Level D Equipment**

Level D protection is worn by personnel who may be exposed only to nuisance contamination during a response. Typically, workers involved with support activities such as equipment supply, vehicle operation in clean zones, or perimeter control may wear Level D.

Level D may appear like “typical work clothes.” Differences include the chemical-resistant boots with steel shanks.

A general rule for which level of protection to use is: **“The less you know, the higher you go.”**

### **Remembering Levels of Protection**

A helpful way to remember the levels of protection is:

Level A - "A"ll Covered, gas/mist tight

Level B - "B"reathing Air, splash protection

Level C - "C"artridge Respirator or air-purifying respirator

Level D - "D"on't Expect Protection", regular work clothes

**Note: Levels A and B suits must be tested. See:**

- 29 CFR 1910.120, Appendix A - PPE Test Methods
- ASTM F23.50.01, Practice for Pressure Testing of TECP
- NFPA 1991, Standard on Vapor-Protective Suits for Hazardous Chemical Emergencies (EPA Level A)
- NFPA 1992, Standard on Liquid Splash-Protective Suits for Hazardous Chemical Emergencies (EPA Level B)
- ANSI/ISEA-101-1996, Limited-Use and Disposable Coveralls - Size and Labeling Requirements
- Chemical-Resistant Clothing: ASTM F739, Permeation; ASTM F903, Penetration

### **Exercise – Levels of Protection**

---

For several ammonia exposure situations and response tasks, work in small groups to identify the level of protection required for each. Several scenarios are provided; your facilitator or you and your group may add or replace these to be more relevant to expected work. Include scenarios that require at various levels of protection (See Exercise Manual for several examples and add more.) Be ready to discuss your choices during a report back.

## Penetration, Degradation, Permeation of CPC

Chemicals can reduce the effectiveness of CPC garments through penetration, degradation, or permeation.

NOTE: Mixtures of chemicals may behave differently from the components.

**Penetration** is the flow of a chemical through zippers, stitched seams, or imperfections in the material.



**Degradation** is a reduction in one or more physical properties of a protective material due to contact with a chemical, use or ambient conditions such as sunlight or cold. This may be seen by swelling or ‘gumminess’ of the material, discoloration or loss of strength.

**Permeation** is the process by which a chemical moves through a material on a molecular level. The rate of permeation is dependent on six major factors:

- Contact time
- Material thickness
- Concentration
- Temperature
- Physical state of chemicals
- Size of the contaminant molecules and pore space

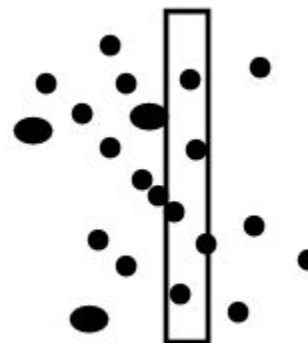

A general rule of thumb is that the permeation rate is inversely proportional to the thickness ( $2 \times \text{thickness} = 1/2 \times \text{permeation rate}$ ). Other important factors are chemical concentration, contact time, temperature, material grade, humidity, and solubility of the material in the chemical. Consult the manufacturer for more information.

A chemical may not degrade a material but may permeate it.

## Chemical-Resistant Materials

---

The following is a list of some commonly used chemical-resistant materials and their advantages and disadvantages. Materials for chemical protection may be blended or laminated and require manufacturer's data when determining proper selection(s). This list should not be used to select materials; manufacturer's guidelines and other references should be consulted.

### Butyl Rubber

**Use** Mainly in encapsulating suit, but some gloves, boots, and splash gear.

**Advantages** Good for bases and many organics. Very resistant to gas/vapor permeation. Readily releases contamination. Good heat and ozone resistance.

**Disadvantages** Poor for aliphatic and aromatic hydrocarbons, gasoline, halogenated hydrocarbons, and abrasion resistance. More expensive than PVC or neoprene.

### Chlorinated Polyethylene (CPE)

**Use** Only in fully encapsulating suits

**Advantages** Good for aliphatic hydrocarbons, acids and bases, alcohols, and phenols. Resists abrasion and ozone.

**Disadvantages** Poor for amines, esters, ketones, and halogenated hydrocarbons. Becomes very rigid when cold.

### Natural Rubber

**Use** For boot covers because of durability and for disposable inner and outer gloves.

**Advantages** Good for bases, alcohols, and dilute acids. Inexpensive. Flexible.

**Disadvantages** Poor for organic chemicals. Ages (affected by ozone).

### Neoprene

**Use** In all types of protective clothing.

**Advantages** Better than polyvinyl chloride (PVC) for organics. Durable. Abrasion- and cut-resistant.

**Disadvantages** Not as good as PVC for acids and bases. Poor for chlorinated aromatic solvents, phenols, and ketones. More expensive than PVC.

### **Nitrile Rubber**

**Use** In gloves and boots and one encapsulating suit.

**Advantages** Made specifically for petroleum products. Abrasion- and cut-resistant. Flexible. Good for bases, peroxides, PCBs, phenols, and alcohol.

**Disadvantages** Poor for aromatic and halogenated hydrocarbons, amines, ketones, and esters. Loses flexibility in cold weather.

### **Polyurethane**

**Use** In boots and splash gear.

**Advantages** Good for bases and organic acids, oils, and alcohols. Abrasion-resistant. Flexible (especially in cold weather).

**Disadvantages** Poor for inorganic acids and other organic solvents.

### **Polyvinyl Alcohol (PVA)**

**Use** For gloves only.

**Advantages** Excellent (the best) for oils, aromatic solvents, and chlorinated hydrocarbons. Ozone-resistant.

**Disadvantages** Degraded by water. Not flexible. Expensive.

### **Polyvinyl Chloride (PVC)**

**Use** All types of protective clothing.

**Advantages** Excellent for acids and bases. Very durable. Relatively inexpensive.

**Disadvantages** Poor for chlorinated and aromatic solvents. Difficult to decontaminate.

### **Viton**

**Use** In fully encapsulating suits and gloves.

**Advantages** Good for most organics including chlorinated hydrocarbons. Fair



durability. Good for acids. Good for decontamination. Good for physical properties.

**Disadvantages** Poor for oxygenated solvents—aldehydes, ketones, esters, and ethers. Expensive.

### **Teflon**

**Use** In fully encapsulating suits.

**Advantages** Excellent chemical resistance against most chemicals.

**Disadvantages** Limited permeation test data. Expensive.

### **Nomex**

**Use** For flame retardant PPE and a base fabric for some suits.

**Advantages** Fire-resistant. Durable.

**Disadvantages** Readily penetrated.

### **Tyvek®**

**Use** Predominantly for coveralls.

**Advantages** Dry particulate and dust protection. Disposable, lightweight, and inexpensive.

**Disadvantages** Penetrable if not chemically treated. Poor durability.

### **Polyethylene (coated Tyvek®)**

**Use** Predominantly for coveralls, but also gloves and booties. It can be worn over CPC to prevent gross contamination of non-disposables.

**Advantages** Good for acids and bases, alcohols, phenols, and aldehydes. Good for decontamination (disposable) and lightweight.

**Disadvantages** Poor for halogenated hydrocarbons, aliphatic and aromatic hydrocarbons. Not very durable. Easily penetrated (stitched seams).

### **Polyethylene/Ethylene vinyl alcohol (PE/EVAL) – 4H® or Silvershield®**

**Use** Gloves, aprons, sleeves and booties

**Advantages** Good for alcohols, aliphatics, aromatics, chlorines, ketones and esters, economical

**Disadvantages** Poor fit of gloves impacts dexterity, easily punctured.

### **Trellchem®**

**Use** Fully-encapsulating and partially-encapsulating suits

**Advantages** Resistant to a wide range of chemicals, some models also including chemical warfare agents, abrasion resistance and flame resistance.

**Disadvantages** Stiff and bulky, expensive

### **Tychem®**

**Use** Fully-encapsulating and partially-encapsulating suits, coveralls and hoods

**Advantages** Resistant to a wide range of chemicals. Some models also resist chemical warfare agents, puncture and abrasion, heat, arc flash and flame.

**Disadvantages** Expensive, stiff and bulky

See resources from manufacturers when selecting CPC. The rating for a material does not necessarily predict performance of a garment; thickness, formulation, substrate and manufacturing process can all affect the product performance.

## **Precautions When Wearing CPC**

---

Every level of chemical-protective clothing has limitations. The following precautions should be considered:

- Hearing and speaking to be heard may be difficult in CPC with respiratory protection. It is important to establish other ways to communicate with each other. Hand signals or audio signals such as horns, sirens, and whistles can be used to communicate. Communication can also be improved by using two-way radios, such as a portable radio with microphone or radio with a microphone and speaker combination attached to the full-face respirator. Reminder: any radio must be intrinsically safe to prevent an ignition hazard. Be aware of potential traffic hazards.

- Due to the size, weight and design of some suits, motion is restricted, especially when climbing, working in tight areas, or using hand tools.
- Look for signs of heat stress (dizziness, headache, nausea, perspiration ceases), especially at temperatures over 70°F.
- Always wear the correct size of footwear in order to prevent accidents. You should also make certain that the soles provide a proper grip for the surfaces that you will be encountering. Steel shanks, toes, and shin guards help to prevent puncture wounds and/or crushing injuries.
- Disposable booties may be slippery. Use caution when walking to prevent slips and falls.
- Care should be taken when donning and doffing inner and outer gloves. When donning gloves, make sure that no cracks or tears are present. When doffing gloves, take care not to spread contamination.
- All joints such as suit-to-boots and suit-to-gloves in Levels B and C protection should be secured with tape that is compatible with the CPC; see manufacturer recommendations. Fold the end of the tape back under to make a tab for easy removal. Use special care when removing tape.
- Goggles and eye/face protection may become clouded due to moisture condensation during use. Follow manufacturer recommendations regarding use of antifog films or spray on protective eye/face gear. Similarly, follow manufacturer instructions regarding clearing away any fog that may form on the inside the face shield of a totally encapsulating suit.
- Be sure you are adequately hydrated prior to and after use of CPC.
- Avoid placing your hands or knees on potentially contaminated surface or the ground to prevent contamination by chemicals and abrasion to the suit material. Avoid sitting on anything sharp in suits.

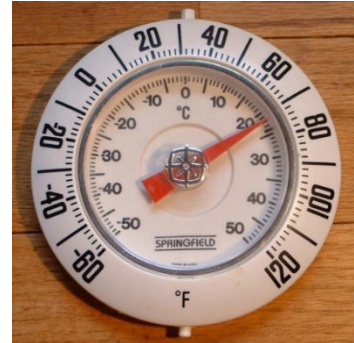

- When removing a suit, open and fold the material down onto itself as it is removed to prevent contamination of internal clothing.
- Suits have weak seams, especially if they are disposable. Be careful not to strain and split them. If splitting occurs, report it and follow the appropriate SOP (standard operating procedure) to obtain protections.
- Use caution when suits are used in potential fire areas. If fire occurs, get out of the area.
- When dressing out with a team be careful to coordinate your dressout at the same speed and level as your team/buddy. The longer you are dressed out, the more stress is being put on your body.
- Completion of dressout should be delayed until ready to conduct your assigned duty/response activity.

## **Inspection, Maintenance, and Storage of CPC**

---

It is important to inspect CPC, for evidence of chemical damage. CPC that is torn, degraded, or otherwise non-functional will not offer adequate protection to the wearer. The PPE program should describe or reference SOPs for CPC inspection, maintenance, and storage.

The inspection SOP is used when CPC is:

- Received from the distributor
- Issued to responders
- Put into storage
- Taken out of storage
- Used for training
- Used for an emergency response
- Sent for maintenance
- Returned from repair or service

An inspection checklist should be developed for each item. Factors to consider are:

- Cuts, holes, tears, swelling, and abrasions in seams of fabric
- Weakness in zipper or valve seals
- Signs of contamination such as discolorations or visible chemical residues
- Signs of malfunctioning exhaust valves

**Note: CPC may be contaminated or degraded even though there are no visible signs.**

Proper maintenance can prolong the useful life of CPC. A detailed SOP must be developed by the employer and followed rigorously. All maintenance must be performed by trained personnel. Know who to contact when needed maintenance is identified.

Proper storage is important in order to prevent CPC failures when used. The written SOP should describe storage before the CPC is issued to the responder, as well as storage after use. Check the manufacturer data for specific temperature and humidity storage requirements, shelf life and any expiration date.

The facilitator will show selected CPC, appropriate for ammonia response work.

### **Donning and Doffing PPE**

---

Proper donning and doffing of PPE will preserve the integrity of the PPE, protect the wearer from chemical exposure and may facilitate efficient decon.

### **Exercise – Level C Dressout and Level C PPE Checkout**

---

This exercise will give you the opportunity to practice donning and doffing and inspecting Level C protection. (See Exercise Manual, agenda)

### **Exercise – Level B Dressout**

---

This exercise will give you the opportunity to practice donning and doffing and inspecting Level B protection. (See Exercise Manual, agenda)

### **Exercise – Level A Dressout—optional, depending on need**

---

This exercise will give you the opportunity to practice donning and doffing and inspecting Level A protection. (See Exercise Manual, agenda)

### **Summary – Chemical-Protective Clothing**

---

The four levels of protection combine RPE, CPC and foot protection as summarized below:

**Level A provides the most protection and includes:**

- A positive-pressure, full facepiece SCBA or supplied-air respirator with escape unit
- A totally encapsulating chemical-protective suit. Inner and outer chemical-resistant gloves
- Chemical-resistant boots with steel toe and shank

**Level A protection is required when:**

- The hazardous substance has been identified and requires the highest level of protection for skin, eyes, and respiratory system
- There is potential for splash, immersion, or exposure to vapors, particulates, or gases that are harmful to the skin or may be absorbed through the skin
- Confined space entry may be involved and the need for Level A cannot be ruled out (but explosion hazard has been ruled out)
- The skin absorption hazard may likely result in immediate death or serious illness/injury or impair the ability to escape

**Level B includes:**

- A positive-pressure, full facepiece SCBA or supplied-air respirator with escape unit
- Hooded, chemical-resistant clothing
- Inner and outer chemical-resistant gloves
- Chemical-resistant boots with steel toe and shank

**Level B protection is required when:**

- The highest level of respiratory protection is needed but a lower level of skin protection (than Level A) is acceptable
- The substances have been identified
- An SCBA is required
- Less skin protection is needed. (Vapor and gases are not believed to be present at high levels harmful to skin or capable of being absorbed through intact skin)

**Level C includes:**

- Full-face air-purifying respirator (APR)
- Hooded, chemical-resistant clothing

- Inner and outer chemical-resistant gloves
- Chemical-protective boots with steel toe and shank

**Level C provides protection when:**

- The concentration(s) and type(s) of airborne substance(s) are known and the criteria for using an air-purifying respirator are met
- Direct contact with the hazardous substance will not harm the skin or the substance will not be absorbed through any exposed skin
- Air contaminants have been identified, concentrations measured, and an air-purifying respirator is available with an acceptable protection factor
- An adequate level of oxygen ( $\geq 19.5\%$ ) is available and all other criteria for the safe use of air-purifying respirators are met

**Level D includes:**

- Coveralls
- Chemical-resistant boots with steel toe and shank

**Level D is required when:**

- Minimal protection from chemical exposure is needed. It is worn to prevent nuisance contamination only
- The atmosphere contains no known hazards that require skin or respiratory protection
- Work functions preclude splashes, immersion, or the potential for unexpected inhalation of or contact with hazardous levels of any chemicals

PPE is selected based on anticipated hazards during the response; a written program must be available to guide the selection, inspection, cleaning, storage and maintenance. Responders must be trained in the use and limitations of assigned PPE. You must be able to inspect PPE and report possible deficiencies and properly comply with cleaning, storage and maintenance protocols included in the written PPE Program.

The advantages and disadvantages when using various chemical-resistant materials can be found in charts and learned from manufacturers.

The effectiveness of protection is reduced by many factors, including:

- Inadequate inspection, storage, cleaning, maintenance
- Penetration, permeation, degradation
- Temperature extremes

- Improper fit
- Use of tape not approved by the manufacturer

Levels A, B or C may be used during a response, depending on the work to be accomplished by each responder. The selection will be determined by the person in charge, according to the pre-planning shown in the ERP.

Special considerations for protective equipment for ammonia responses include:

- Must be resistant to liquid ammonia, ammonia gas/vapor, ammonium hydroxide
- Escaping ammonia may create lower temperatures in the work area. Verify resistance/integrity and flexibility of CPC at lower temperatures.

Procedures to be used for inspection, maintenance and storage are determined as part of pre-planning and included in the PPE program in the ERP.

Motion may be restricted when wearing PPE. Slips and falls could result. Heat buildup in suits can pose a risk of heat stress. Communication is essential to ensure that any health or safety concern can be remediated.

Routine practice donning and doffing protective gear will contribute to an effective response.

A general rule for which level of protection to use is: **“The less you know, the higher you go.”**

### Remembering Levels of Protection

A helpful way to remember the levels of protection is:

Level A - "A"ll Covered, gas/mist tight

Level B - "B"reathing Air, splash protection

Level C - "C"antridge Respirator or air-purifying respirator

Level D - "D"on't Expect Protection", regular work clothes



## **PPE - Other Protective Gear**

---

PPE for hazardous materials responders includes respirators, chemical-resistant suits, boots, gloves, eye protection and hand protection.

PPE is required by OSHA regulations for protection from:

- Chemical contact with skin and eyes. (suits, aprons, gloves, goggles, face shield)
- Respiratory hazards (respirator)
- Physical hazards. (boots, hard hat, gloves, sleeves, thermal protection, hearing protection)

### **Section Objectives**

---

When you have completed this section, you will be better able to:

- Recognize OSHA standards and guidelines from other organizations for hearing, eye/face, hand, head and foot protection

In addition to RPE and CPC, other types of PPE may be required in an emergency response. OSHA standards for additional PPE include:

- 29 CFR 1910.95 Hearing Protection (fire truck siren can exceed 100 dB)
- 29 CFR 1910.133 Eye and Face Protection
- 29 CFR 1910.135 Head Protection

- 29 CFR 1910.136 Foot Protection
- 29 CFR 1910.137 Electrical Protective (gloves and sleeves)
- 29 CFR 1910.138 Hand Protection

With the exceptions of hearing protection and electrical protection, these protective devices are required in one or more of the Levels of Protection (A, B, C, D). General overall guidance for PPE is shown in 29 CFR 1910.132, General Requirements: Personal Protective Equipment.

Guidelines for head, shoe and eye/face protection testing and use are shown in the table below.

Protective Equipment	Use/Testing Guideline
Hard Hats	ANSI Z89.1-2009 Industrial Head Protection ANSI Z89.1-2003 Industrial Head Protection ANSI Z89.1-1997, Protective Headwear for Industrial Workers
Shoes	ASTM F-2413-2005, Performance Requirements for Protective Footwear ASTM F-2412-2005, Test Methods for Foot Protection ANSI Z41-1999, Personal Protection --Footwear ANSI Z41-1991, Personal Protection—Footwear  Note: ASTM F-2413 current version -17 has not been adopted by OSHA
Eye/Face	ANSI Z87.1-2010, Occupational and Educational Eye and Face Protection Devices ANSI Z87.1-2003, Occupational and Educational Eye and Face Protection Devices ANSI Z87.1-1989, Occupational and Educational Eye and Face Protection

**Noise/Communication**

During a response, noise levels from alerting signals and other sources may be very high. Short exposures to high noise levels can cause a temporary change in hearing or the sound of ringing in your ears. Repeated exposures over longer periods of time to noise can lead to permanent effects, including hearing loss. Exposure to high noise

levels is also linked to high blood pressure, insomnia, headaches and psychological stress.

Loud noise in the workplace can interfere with communication and concentration resulting in lower productivity, accidents and injuries.

See noise exposure level for operating heavy equipment, below.

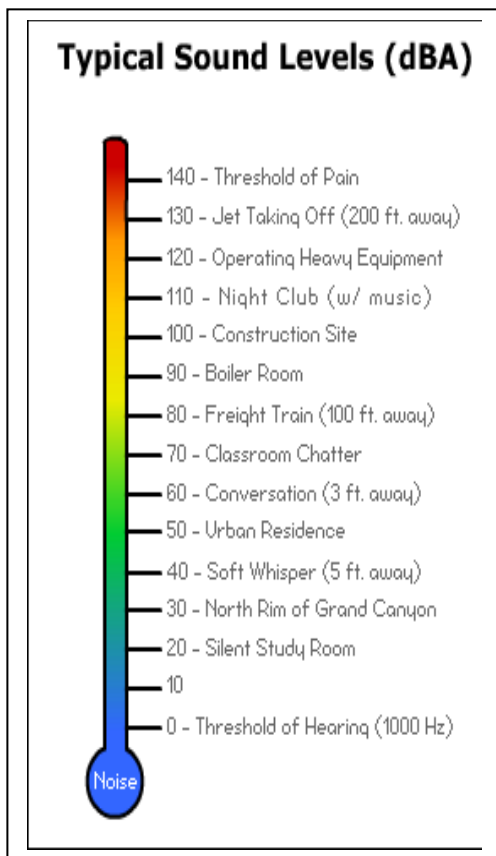

Notice that the values are shown in dBA, or decibels (dB) measured on the A-weighting scale. This scale mimics the human ear response to sound; it does not measure some of the low frequency sound, as the human ear does not pick up all low frequency sound. Occupational exposure to noise is measured on this scale. dB and dBA cannot be compared easily.

Other useful noise levels are:

Impact wrench	105 dBA
Ambulance siren	120 dBA
Air horn alert system	130 dBA

Over an 8-hour shift, OSHA allows a TWA exposure of 90 dBA. If the sound is louder, less time is allowed; for example, 4 hours is allowed at a TWA of 95 and 2 hours is allowed at a TWA of 100. If the TWA exceeds 85 dBA, a Hearing Conservation Program is required to monitor hearing, provide training and hearing protection. See 29 CFR 1910.95.

NIOSH and ACGIH recommend lower exposures.

source:

<https://www.osha.gov/SLTC/noisehearingconservation/loud.html>

NIOSH provides an app for noise measurement. See

<https://www.cdc.gov/niosh/topics/noise/app.html>

Communication during any IDLH situation is required and critical for the safety of responders.

Noise exposure levels in an engine room for a refrigeration unit make communication extremely difficult. An earmuff system with communication inside is one option. Conduct a 'test run' use of any product in your own plant prior to purchase to assure that it meets the needs of responders and other employees. Communication during any

IDLH situation is required and critical to the safety of responders.

## **Summary – Other Protective Gear**

---

OSHA standards cover

- Hearing Protection
- General Requirements: Personal Protective Equipment
- Eye and Face Protection
- Head Protection
- Foot Protection
- Electrical Protective (gloves and sleeves)
- Hand Protection

Other specialized clothing includes high-temperature and arc flash protection.

ANSI publishes guidance on the testing of hard hats, safety shoes and eye/face protection.

# Material Identification

---

Recognizing a potential hazard is an important step toward avoiding it during a hazardous materials response.

This section includes resources that will help you identify anhydrous ammonia sources based on the container shape or labels or written programs.

## Learning Objectives

---

When you have completed this section, you will be better able to:

- Identify anhydrous ammonia containers based on shapes and sizes
- Identify label information on piping systems including specifications of the International Institute of Ammonia Refrigeration (IIAR)
- Identify label information in the Hazard Communication standard or other systems including NFPA 704, DOT, HMIS for containers
- Identify other resources for hazmat information available with shipments
- Demonstrate an ability to identify health and safety information using resources

## **Container Shapes and Sizes**

---

Containers are used to store and ship materials. In an emergency at a fixed site or in transit the labels or placards may be damaged or blocked from view. Therefore, it may be important to recognize specific types of containers. Relevant containers are shown below. Additional information on in-plant containers is shown in the section on Refrigeration systems.

### **Pressurized Rail Tank Cars**

These rail cars have horizontal tanks with rounded ends, unless they are double shelled and have a bonnet (dome cover). These tank cars usually contain flammable and nonflammable gases and poisons.

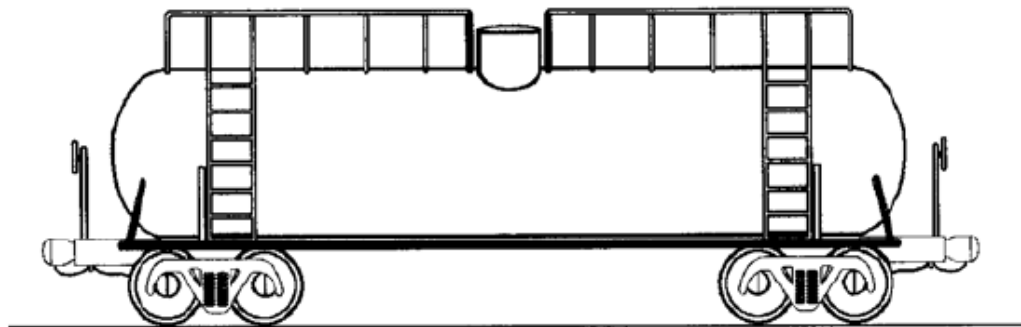

## High-Pressure Liquefied Gas Tanker

These tanks are circular with rounded ends. They may contain propane, butane, or anhydrous ammonia under pressure. MC331, TC331, SCT-331.

Side View

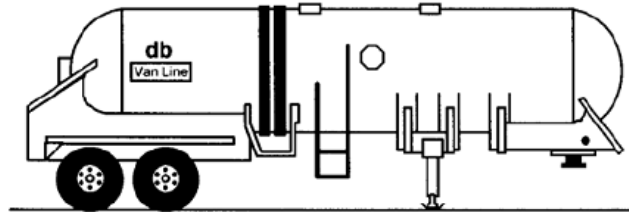

Back View

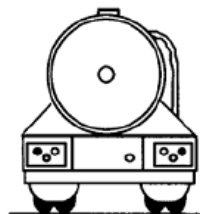

## Cylinders

The emergency responder needs to be aware of the potential danger posed by the presence of cylinders in an emergency.

Cylinders usually contain **pressurized flammable** or **non-flammable gases**. Cylinders on site may contain anhydrous ammonia to recharge the refrigeration system.

Explosion potential of pressurized cylinders should be considered, particularly in fire situations. Ruptures of the cylinders may result in dangerous airborne projectiles.

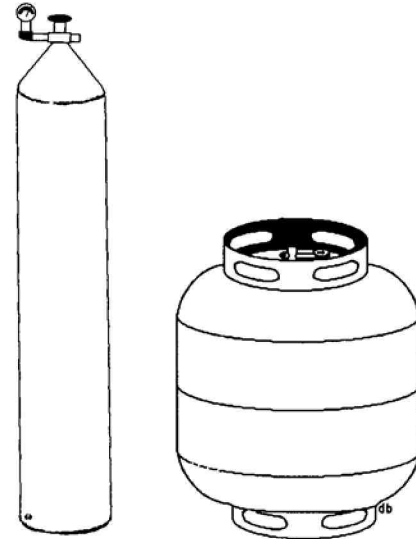

## **Ammonia Refrigeration Systems**

---

Because the focus of this program is ammonia, it is appropriate to review the basic components of a refrigeration system before describing label requirements.

These include:

### Compressor

- Adds work to the refrigeration cycle
- Low pressure, cold gas compressed to raise temperature and pressure

### Condenser

- Hot gas cooled to a hot liquid in an evaporative condenser

### Expansion device

- Temperature and pressure of liquid ammonia is lowered

### Evaporator

- Liquid ammonia absorbs heat from the medium being cooled
- 'Boiling ammonia' changes to a gas for return to the compressor

Because of the complexity of the system, ongoing operation is monitored by computer in a control room. Area alarms are in place to visually or audibly alert workers to unusual conditions and these conditions will be visible on the computer monitoring panels. Alarms may be color-coded and may indicate the level of ammonia. Training in the meaning of alarms and the action you must take for each one is required.

Your facilitator will provide a diagram of the plant system, or a generic system for use in this training. Identification of the major components in the refrigeration cycle is critical for the hazard and risk analysis as part of pre-planning and will be used to select response options during a response.

Monitoring temperature and pressure in a control room is the main 'tool' to determine if the system is working properly.



## **Systems and Symbols**

---

It is important to know the systems which are used to identify hazardous materials. Identification information is included on labels applied to small containers (drums, packages, boxes) and placards applied to large containers (trailers, rail cars, tanks). There are several different systems; one or more may be used at the plant by contract personnel or companies which supply raw materials. Some of these systems are described below.

### **Hazard Communication**

The purpose of the OSHA Hazard Communication Standard is to ensure that everyone at a worksite has access to information about the chemicals that are used and has been trained to use them safely. This information is important for responders who must manage an unexpected release.

The 2012 revision of the Hazard Communication Standard (HCS2012) covered most hazardous chemicals (excluding wastes) in an overall system that looks at physical hazards (such as flammability and corrosivity), health hazards (including both immediate and long-term health effects) and environmental hazards. The revision included major changes in labels for containers and Safety Data Sheets (SDSs), previously referred to as Material Safety Data Sheets, MSDSs). This update of the OSHA standard has the same number (29 CFR 1910.1200) in the Federal Register. See

<https://www.osha.gov/laws-regs/regulations/standardnumber/1910/1910.1200>.

HCS2012 requires all manufacturer labels to have

- pictograms
- a signal word
- hazard statements
- precautionary statements
- product identifier
- supplier identification

The first four of these are new and each is reviewed below for ammonia. Hazard pictograms for ammonia will include



Exclamation point is associated with:

- Irritant (skin and eye)
- Skin Sensitizer
- Acute Toxicity (harmful)
- Narcotic Effects
- Respiratory Tract Irritant



Chemical on surfaces refers to:

- Corrosion
- Skin corrosion/burns
- Eye damage
- Corrosive to metals

These are broad categories, and not all effects may result from ammonia exposure (example, skin sensitizer, narcotic effects)

If the ammonia is shipped/received in cylinders, the gas cylinder pictogram is appropriate, indicating Gas Under Pressure.



The single, required Signal Word for ammonia is DANGER.

The Hazards Statements on ammonia labels will include phrases such as:

- Harmful if inhaled
- Causes severe skin burns and eye damage
- Contains gas under pressure; may explode if heated
- Flammable gas
- May form explosive mixtures
- May displace oxygen and cause rapid suffocation

Precautionary Statements describe a variety of 'good practices' and may be divided into categories, such as general, prevention, response and storage/disposal. Examples include

General: read and follow SDS before use; use backflow device in piping

Prevention: wear eye/face protections; avoid breathing gas

Response: collect spillage; if inhaled, remove person to fresh air, call EMS

Storage/disposal: restrict access; follow regulations

Employers may continue to use rating systems such as National Fire Protection Association (NFPA) diamonds or HMIS requirements (both discussed later in this section) for workplace labels, as long as they are consistent with the requirements of the Hazard Communication Standard and the employees have immediate access to the specific hazard information for the chemicals (for example, in an up-to-date SDS). An employer using NFPA or HMIS labeling must, through training, ensure that employees are fully aware of the hazards of the chemicals used.

**Piping System Labeling**

The piping system in a facility can be extensive. Knowledge of the system and markings used to identify the function of a section of the piping and the nature of the contents is critical information for the responder.

Ammonia piping may be color coded in accordance with the requirements at an individual facility or based on the refrigeration contractor’s recommendations. A labeling system used at one processing plant is shown below:

Symbol	Description
BD	Booster Discharge
CD	Condensation Drain
CR	Condensate Return
ES	Economizer Suction
HG	Hot Gas
HGD	Hot Gas Defrost
HPL	High Pressure Liquid
HSD	High Stage Discharge
HSS	High Stage Suction
LSS	Low State Suction
LTS	Low Temperature Suction
HTS	High Temperature Suction
HTRL	High Temperature Recirculated Liquid
LTRL	Low Temperature Recirculated Liquid
HTRS	High Temperature Recirculated Suction
LTRS	Low Temperature Recirculated Suction
LIC	Liquid Injection Cooling
RV	Relief Valve
TSR	Thermosyphon Return
TSS	Thermosyphon Supply

Many companies use the system recommended by the International Institute of Ammonia Refrigeration (IIAR) and is followed by many refrigeration contractors. The IIAR Bulletin 114 provides guidance on labels but does not address piping colors.

The IIAR specification for piping markers has five sections:

1. marker body
2. physical state section
3. pressure level section
4. abbreviation section
5. directional arrow

For example

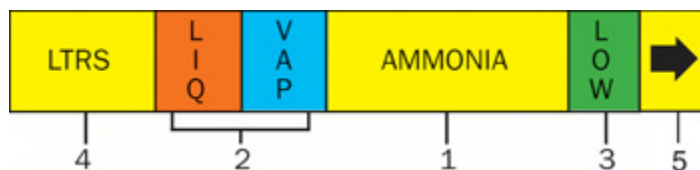

1. The marker body must be in safety yellow color. The AMMONIA must be printed in black letters on the panel.
2. The physical state is shown as liquid (LIQUID, LIQ) on an orange band or vapor (VAPOR, VAP) on a sky-blue band. When the ammonia is usually present in both states, the VAP band is directly to the left of the AMMONIA word, and the LIQ band is left of the sky-blue band, as shown above.
3. The pressure designation has one of two values—HIGH or LOW, to the right of the AMMONIA word. Normal operating pressures less than or equal to 70 psig are designated LOW, printed on a green band as shown above. For normal operating pressures in excess of 70 psig, the word HIGH is printed on a red band.
4. Abbreviations of piping functions common to refrigeration systems assist operators and responders in identifying characteristics.

IIAR-approved abbreviations are:

Abbreviation	Description
BD	Booster Discharge
CD	Condensation Drain
DC	Defrost Condensate
ES	Economizer Suction
HGD	Hot Gas Defrost
HPL	High Pressure Liquid
HSD	High Stage Discharge
HTRL	High Temperature Recirculated Liquid
HTRS	High Temperature Recirculated Suction
LTRL	Low Temperature Recirculated Liquid
LTRS	Low Temperature Recirculated Suction
LIC	Liquid Injection Cooling
LSS	Low State Suction
RV	Relief Valve
TSR	Thermosyphon Return
TSS	Thermosyphon Supply

The abbreviations may be supplemented by showing the normal operating pressure.

5. The direction of flow is shown on the far right of the marker using a prominent black arrow on the safety yellow background.

See Bulletin 114 for additional details on the size of lettering and material for an approved IIAR marker.

**OSHA Process Safety Management of Highly Hazardous Chemicals (PSM, 29 CFR 1910.119)**

Each company required to comply with this standard often referred to as PSM, must implement a system to attach identification tags to each part of the process carrying the chemical. The required diagram of plant refrigeration operations shows tag information. If a responder can read the identifying tag at the source of the leak, this will aid the incident commander and the refrigeration technician in the response to the release. If a

responder is asked to close a valve, the tag will be used with other written programs to verify safety procedures such as lock out/ tag out and preplanned response actions.

### Exercise – Identifying Information on System Labels

---

In this exercise you will use a system layout and the IIAR materials above or employer information to identify the process step, physical state, pressure and direction of flow of ammonia for several labels provided by the Facilitator. (See Exercise Manual)

#### National Fire Protection Association (NFPA)–704 System

The NFPA system is used for storage vessels and stationary containers at an industrial facility.

The NFPA system is used by the Fire Department and transporters but is not required by OSHA; however, if it is used at a facility, the hazard communication training program must include this system.

A placard for anhydrous ammonia is shown below:

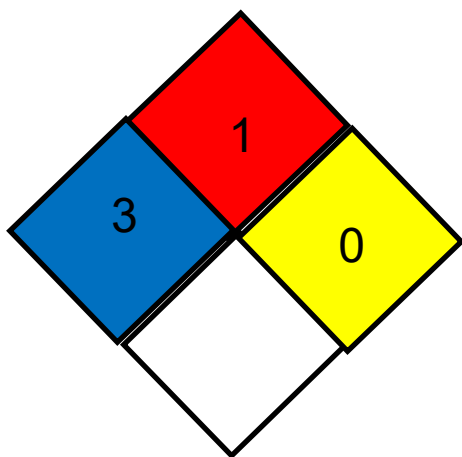

Notice the ...

Shape: diamond

Colors: Red, Blue, Yellow, White

Numbers: 4, 3, 2, 1, 0

White diamond (special hazards):

no entry for ammonia

All NFPA placards and labels are the same shape and have the same colors. What differs are the numbers and symbol.

An explanation of the parts follows:

The color of each of the four small diamonds indicates the type of hazard as shown below.

Color	Hazard
Red	Flammability
Blue	Health
Yellow	Instability
White	Special hazards

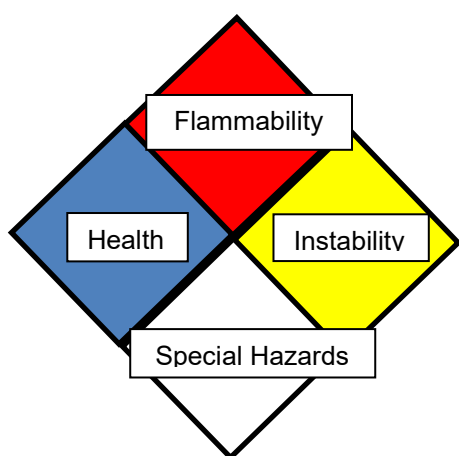

The number in the red, blue, and yellow diamonds is a relative rank of the potential flammability, health, and instability hazard, respectively, ranging from 0 or blank (low) to 4 (high hazard).

The Special Hazards (white) section of the NFPA-704 label may contain symbols (examples shown below) that give more information about the chemical. The following are symbols and their meanings that might be found in the Special Hazards (white) section of the NFPA-704 label.

NFPA Standard Symbols:

~~W~~  
Reacts with water

OX  
Oxidizer

SA  
Simple Asphyxiant

Non-Standard Symbols:

- **COR:** Corrosives
- **ACID** and **ALK** (Alkali) to be more specific
- **BIO:** Biological Hazard
- **POI:** Poisonous Material (e.g. strychnine)
- **CYL or CRYO:** Cryogenic Material (e.g. liquid nitrogen)
- **☼** : Radioactive material (e.g. plutonium, uranium)





This field may also be left blank if no special hazards are present.

Look back at the ammonia placard shown above. Are the numbers shown consistent with the properties of anhydrous ammonia described in previous sections?



The following explanation of the values is provided at Cameo Chemicals (<https://cameochemicals.noaa.gov/chemical/4860>). See the note below the table indicating that the red value should be 3 when placarding/labeling any container refrigeration equipment inside a building.

### NFPA 704

Diamond	Hazard	Value	Description
	 Health	3	Can cause serious or permanent injury.
	 Flammability	1	Must be preheated before ignition can occur.
	 Instability	0	Normally stable, even under fire conditions.
	 Special		

Note: The Refrigeration System Classification section of the International Mechanical Code requires a value of 3 for the red quadrant (flammability hazard) for indoor ammonia refrigeration equipment. (NFPA, 2010)

**The HMIS (Hazardous Material Information System)**

The HMIS is used for storage vessels and containers. Below is an example of an HMIS label for ammonia.

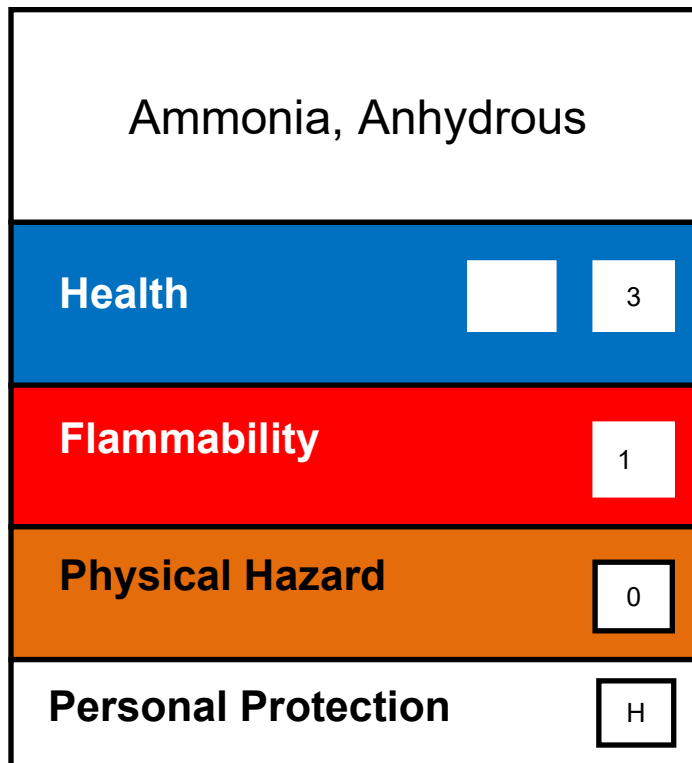

Notice the ....

Shape: Rectangular

Chemical Name: Ammonia, anhydrous

Colors: Blue, Red, Orange, White

Boxes: Contain numbers or letters

All HMIS labels have the same shape and colors. For hazard recognition, it is important to note numbers in the blue, red and orange boxes and any letter in the white section.

The numbers rank the potential health, flammability, and physical hazard and range from 0 (low) to 4 (high).

The Personal Protection section may contain a letter which tells you what personal protective equipment you should use to protect yourself when working with the material. Capital letters range from A (safety glasses) to K (full protective suit with gloves, boots, a hood or mask, and an airline or Self-Contained Breathing Apparatus). If the personal protection is coded X, specialized handling procedures are needed. Lower-case letters n through u, w, y and z are codes for specific protective equipment. For example, H represents eye, skin and respiratory protection. A chart outlining each letter code is shown here:

<http://www.northcampus.net/CHM1025/Lab/LabSafetyHMIScodesSp2012.htm>.

Two boxes may appear next to *Health*. The first box contains an asterisk (\*) if the material poses a risk of a chronic health effect; otherwise, a slash (/) should be in the box. The box on the right contains the numerical hazard rating (0–4). Alternatively, the two symbols may be combined in the box on the right. For example, 3\* in the box on the right would mean a serious chronic health effect.

**NOTE OF CAUTION:** While HMIS and NFPA 704 are US systems that have been in place for many years, the transition to a globally harmonized approach as in HCS2012 may cause confusion. It is very important to recognize that the numbering system in the two approaches is not consistent—and is in fact opposite as shown below.

HCS2012 Hazard categories		HMIS/NFPA 704 numerical ratings	
1	Severe Hazard	0	Minimal Hazard
2	Serious Hazard	1	Slight Hazard
3	Moderate Hazard	2	Moderate Hazard
4	Slight Hazard	3	Serious Hazard
5	Minimal Hazard	4	Severe Hazard

**Emergency Response Guidebook–System of Placards and Labels (ERG, enforced by the US Department of Transportation, DOT)**

The HCS2012 pictograms do not replace the diamond-shaped labels that DOT requires for the transport of chemicals, including chemical drums, chemical totes, tanks or other containers. Those labels must be on the external part of a shipped container and must meet the DOT requirements set forth in 49 CFR 172, Subpart E. If a label has a DOT transport pictogram, HCS pictograms for the same hazard may also appear on the label. While the DOT diamond label is required for all hazardous chemicals on the outside of shipping containers, chemicals in smaller containers inside the larger shipped container show the OSHA pictogram label, not the DOT diamond.

The DOT system is used in the transportation of hazardous materials and applies to rail cars, road trailers, and shipped containers.

Below is an example of a DOT signage or label that might be seen on an over-the-road trailer or rail car containing ammonia.



Notice the... Shape: diamond  
 Color: green  
 Symbol: cylinder  
 4-digit number: 1005  
 1-digit number: 2

All DOT placards are the same shape but differ in the other 'clues' that are shown.

The green color of this placard indicates that the contents are non-flammable.

A full listing of the hazard for each color is shown below:

<b>Color</b>	<b>Hazard</b>
Orange	Explosive
Red	Flammable
Green	Non-flammable
Yellow	Reactive
White with skull and crossbones	Toxic or corrosive
White and red vertical stripes	Flammable solid
White top with black bottom	Corrosive
White top with red bottom	Spontaneously combustible
Yellow top with white bottom	Radioactive
Blue	Water-reactive
Black and white stripes on top, white bottom	Low to moderate hazard

The cylinder symbol of the placard above indicates that the chemical is a non-flammable gas. Other symbols for specific hazards are shown in the table below:

Symbol	Hazard
Red flame	Flammable
Bursting ball	Explosive
Blue Flame	Flammable
W with slash	Dangerous when wet
Skull and crossbones	Poisonous
Circle and flame	Oxidizing material
Propeller/Trefoil	Radioactive
Test tube/hand/metal	Corrosive
Special symbol	Infectious

A **four-digit** number in the **center** identifies a specific compound. These numbers are identified in the *Emergency Response Guidebook*. For example, 1005 is anhydrous ammonia. This number may be in the center of the placard (number placards) or on an orange-colored panel below the placard, along with a “word placard” the compressed gas cylinder. For ammonia this would be:

**1005**

Number placards must be displayed on large portable tanks, tank trucks, and rail cars. A word placard means that drums or smaller containers are present.



The **one-digit** number at the **bottom** is the Hazard Identification Code.

#	UN Hazard Class
1	Explosives
2	Gases (compressed, liquefied, or dissolved under pressure)
3	Flammable liquids
4	Flammable solids: spontaneous combustible and Dangerous when wet/ Water Reactive
5	Oxidizing substances and organic peroxide
6	Poisonous, poison inhalation hazard, and infectious substances
7	Radioactive substances
8	Corrosives
9	Miscellaneous hazardous materials

You can find more information on what these numbers and symbols mean in a DOT Chart and the *Emergency Response Guidebook*. See Divisions under classes 1-7. For example, Class 2 (Gases) is further divided into:

- Division 2.1 Flammable gases
- Division 2.2 Non-flammable, non-toxic gases
- Division 2.3 Toxic gases

**Note:** While the North American ERG placard for anhydrous ammonia is a Division 2.2 non-toxic gas, the International Maritime Organization placard requirements designate it as a 2.3 poisonous gas. The LEL/UEL values are consistent with definition of flammable gas in 29 CFR 1910.1200 Appendix B.

The 2016 ERG can be downloaded onto your device for free. Here are the links for each device:

Android (at Google store):

<https://play.google.com/store/apps/details?id=gov.nih.nlm.erg2012&hl=en&gl=us>

iPhone or iPad (at iTunes):

<https://itunes.apple.com/us/app/erg-2016/id592158838?mt=8>

Windows: <https://www.phmsa.dot.gov/hazmat/erg/erg2016-windows-software>

To use the guidebook, you need to know either the chemical name or the identification number.

If you know the **name**, look in the blue pages to find the guide number. Once you have the correct guide number, proceed to the white pages with orange edges, where you will find more detailed information on the chemical.

If you know the **UN number**, look in the yellow pages to find the guide number. Once you have the correct guide number, proceed to the white pages with orange edges to find more detailed information on the chemical.

Use Table 1 for initial isolation and downwind protective distances for spills (large and small) occurring during the day or at night. Use Table 3 to identify the same parameters for several important industrial chemicals (ammonia, chlorine, ethylene oxide, hydrogen chloride, hydrogen fluoride and sulfur dioxide) by spill size, wind speed, day or night and shipping container (rail tank car, highway tanker, multiple ton cylinders, and multiple small or single ton cylinder).

### Activity – Using the ERG

---

In this activity you will use the ERG to identify initial isolation distances for conditions specified by the facilitator. (See Exercise Manual)

### Written Documents

---

Written documents are available describing the hazardous chemicals and materials. Two important on-site sources of ammonia information are shipping papers and Safety Data Sheets (SDSs). As part of the Emergency Response Plan, it is important to know where these resources are found and the types of information each contains.

#### Shipping Papers

Each shipment of hazardous materials must have paperwork documenting the specific contents of the shipment and relevant information. When hazardous and non-hazardous materials are listed on the same shipping paper, the hazardous materials must be listed first or emphasized by bold font or contrasting color. This paperwork has different names depending on the type of transportation vehicle.

<b>Transportation</b>	<b>Location during transport</b>	<b>Common name(s)</b>
Truck	In the cab	Bill of Lading Waste Profile Sheet
Train	With the conductor	Waybills, Consists, Wheel Reports, Train List

A copy of the shipping papers is given to plant personnel upon arrival at the delivery site. A copy is retained showing the date of acceptance by the initial carrier. Papers are retained by the shipper for 2 years and the carrier for 1 year. Hazardous waste manifests are kept for 3 years by both the carrier and shipper. These must be accessible at the principle place of business and available upon request.

Shipping papers are required by the Department of Transportation (DOT). The shipper of the material provides this information.

The proper description for shipping hazardous cargo includes the following 4 categories:

- Basic description
- Additional information, depending on the material and the mode of transport
- The quantity of the hazardous material
- The type of packaging used

The basic description should include:

- Identification number
- Proper shipping name
- Hazard class
- Packing group

The order in which this information must be shown is given in 49 CFR 172, Subpart C.

The shipper must provide a certification statement, certifying that the shipment complies with the HMR. The shipping papers must also contain an emergency response telephone number, unless exempted. This number must always be monitored by a knowledgeable person while the shipment is underway.

The following information must be shown on a Bill of Lading:

- Proper shipping name found in the Hazardous Materials Table (HMT) in the HMR
- Hazard class or division number (subsidiary risks)



- Identification number packaging group
- Total quantity being shipped
- Special permits (Examples) DOT-SP, DOT-E
- Emergency Response telephone
- Empty Package
- Transport Modes
- Shipper's Certification
- Packing group
- Marine Pollutants- Vessel mode (non-bulk)
- Poison or toxic inhalation (add info/continuation pages)
- Limited Quantity Hazardous Substance Reportable Quantity (RQ)
- Radioactive

### **Safety Data Sheets (SDSs)**

SDSs are required by the OSHA Hazard Communication Standard (29 CFR 1910.1200). The SDS consists of 16 required sections as shown on the OSHA Quick Card: Hazard Communication Safety Data Sheets on the next page. Regardless of manufacturer, the order of the information must be in the order required by OSHA.

Workers must be trained in using SDSs to find information and to work safely with any materials that are used, on-site or off-site.



## Hazard Communication Safety Data Sheets

---

The Hazard Communication Standard (HCS) requires chemical manufacturers, distributors, or importers to provide Safety Data Sheets (SDSs) (formerly known as Material Safety Data Sheets or MSDSs) to communicate the hazards of hazardous chemical products. As of June 1, 2015, the HCS will require new SDSs to be in a uniform format, and include the section numbers, the headings, and associated information under the headings below:

**Section 1, Identification** includes product identifier; manufacturer or distributor name, address, phone number; emergency phone number; recommended use; restrictions on use.

**Section 2, Hazard(s) identification** includes all hazards regarding the chemical; required label elements.

**Section 3, Composition/information on ingredients** includes information on chemical ingredients; trade secret claims.

**Section 4, First-aid measures** includes important symptoms/ effects, acute, delayed; required treatment.

**Section 5, Fire-fighting measures** lists suitable extinguishing techniques, equipment; chemical hazards from fire.

**Section 6, Accidental release measures** lists emergency procedures; protective equipment; proper methods of containment and cleanup.

**Section 7, Handling and storage** lists precautions for safe handling and storage, including incompatibilities.

**Section 8, Exposure controls/personal protection** lists OSHA's Permissible Exposure Limits (PELs); Threshold Limit Values (TLVs); appropriate engineering controls; personal protective equipment (PPE).

**Section 9, Physical and chemical properties** lists the chemical's characteristics.

**Section 10, Stability and reactivity** lists chemical stability and possibility of hazardous reactions.

**Section 11, Toxicological information** includes routes of exposure; related symptoms, acute and chronic effects; numerical measures of toxicity.

**Section 12, Ecological information\***

**Section 13, Disposal considerations\***

**Section 14, Transport information\***

**Section 15, Regulatory information\***

**Section 16, Other information,** includes the date of preparation or last revision.

\*Note: Since other Agencies regulate this information, OSHA will not be enforcing Sections 12 through 15(29 CFR 1910.1200(g)(2)).

**Employers must ensure that SDSs are readily accessible to employees.** See Appendix D of 1910.1200 for a detailed description of SDS contents. For more information: [www.osha.gov](http://www.osha.gov)

## Limitations of Written Documents

---

Although the SDSs, shipping papers, manifest forms, and waste profile sheets contain important information, they have several limitations. Some of these are listed below.

- Limited information:
  - Information may be incomplete or inaccurate
  - Space on the form may be inadequate
  - Information may not be relevant for the site or specific use
  - Information may be too general for use
  - SDS may not be current
  - Insufficient time to read and understand the information, particularly in an emergency
  - Insufficient time to call manufacturer/supplier contact, particularly in an emergency
  
- May not be readily available:
  - Not included in hazard assessment documentation
  - Not accessible if electronic systems are damaged or access to location blocked by the emergency
  - In some rural areas, cell or internet access may be limited
  
- May not be accurate
  - One of the most frequent violations of the Hazardous Materials Regulations (HMR) 49 CFR Parts 100-185 is a failure to properly describe the hazardous material on the shipping papers.

### **Activity – Optional, Using an SDS**

As appropriate, the facilitator will provide an exercise using an SDS for ammonia.

**OR**

### **Activity – Optional, Electronic Resources**

As appropriate, the facilitator will provide an exercise using electronic resources for ammonia Hazard Assessment. (See Exercise Manual)

### **Summary–Material Identification**

As an emergency responder, you may encounter a variety of hazards during an ammonia release; using container shapes, labels and markings and written documents to identify hazards will help you avoid exposure to hazardous materials and protect your health and safety.

The in-plant label system is critical to identifying process information. The systems for marking piping in a facility must be known to responders before an incident. Knowledge of the piping markings will assist in conducting the response and in the documentation needed at termination.

The Emergency Response Guidebook (ERG) contains information on placards and road and rail containers and stationary storage containers.

# MONITORING

---

Detecting and measuring hazardous substances at a response is very important to protect safety and health and the environment. Anhydrous ammonia can be detected and measured using a variety of different monitoring instruments.

Exposure levels have been set by government agencies as well as non-governmental organizations. These levels and limits are used to guide response objectives and select proper protective equipment to ensure a safe response.

## Learning Objectives

---

When you have completed this section, you will be better able to:

- Describe reasons to monitor during a response
- Identify features (including limitations) of ammonia monitors
- Describe procedures required when conducting monitoring at an ammonia response
- Demonstrate proficiency in using ammonia monitoring devices

## The Importance of Monitoring

Monitoring provides important information about the presence of hazardous substances such as ammonia at an emergency. Readings or samples of the atmosphere are taken regularly and in different locations. Although no single instrument may be useful in all situations, proper use of air-sampling equipment can provide information needed to protect life and property. Using the wrong type of instrument may provide information that results in responders being exposed to an unsafe environment.

## Uses for Monitoring Data

Detect potential hazards to:

- Determine possible immediate effects of hazards, especially conditions that are Immediately Dangerous to Life and Health (IDLH) such as LEL or ammonia concentration before and during response actions
- Identify changes in or a sudden release of ammonia that would require new emergency action during the response
- Determine that the hazards have been remediated when the response has ended

Measure concentrations to:

- Determine the extent of the hazardous condition
- Assist in planning response actions
- Provide records of exposure for medical purposes
- Provide a historical record to submit to regulatory agencies

Most ammonia leaks are small.

**Detect:** The typical area ammonia monitor is set to alarm at 25-50 ppm and may be linked to automatically activate an exhaust fan. The initial actions following an alarm are shown in the PSM EAP or the HAZWOPER ERP.

**Measure:** The location and concentration will be used to determine if the leak is handled under PSM or according to the ERP.

This section covers preparation for and conduct of monitoring activities related to a 29 CFR 1910.120 emergency response to an ammonia release.

## **Monitoring at an Emergency**

---

### **General considerations**

It is important to carefully monitor the atmosphere during a response to an unexpected release. Failure to recognize toxic, explosive, or oxygen-deficient or oxygen-enriched atmospheres could result in serious damage to life and property. The ERP provides a plan for monitoring as part of the emergency response.

Monitoring will be performed when there is a question as to whether responders may be exposed to hazardous substances; the results are used as one factor in selecting PPE. Air monitoring will usually be conducted as part of initial actions and throughout the response to ensure that the proper level of PPE is used by the responders. In addition, it is often necessary to document concentrations at the perimeter or in other locations near or adjacent to the response such as downwind, where contaminants may be transported. Specific SOPS developed in advance and included in the ERP are followed. Where monitoring will not be conducted, the reasons must be listed in response documentation.

Monitoring data will be used for specific purposes before and throughout the response and may include:

### **Pre-Emergency (pre-planning)**

Background or usual levels may be available from routine monitoring or might be determined in advance as a training exercise

### **Emergency**

- Determining whether entry can be made
- Providing information for the response strategy
- Determining level of PPE protection
- Monitoring conditions, in case of change

### **Post-Emergency**

- Establishing levels after containment/confinement
- Documenting perimeter levels
- Identify post-emergency response needs during termination
- Completing termination documents

Some general considerations during various phases of the response follow:

**Pre-planning**

- Monitoring equipment appropriate for anticipated levels of ammonia exposure should be available
- Members of the emergency response team who are expected to use the equipment must be trained in its use during a response, including protecting the device from damage or contamination
- Emergency response team members should practice using the equipment during emergency response drills
- Equipment must be properly maintained and stored so it is ready for use during an emergency
- Spare parts should be available to trained personnel to repair the equipment in case it is damaged during response activities. Alternatively, back-up equipment should be available, and a repair service identified for contact as needed

**Before using an instrument to detect or measure**

- Review manufacturer recommendations and procedures
- Allow adequate warm-up time as appropriate
- Calibrate equipment as appropriate
- Cover with plastic to prevent contamination as appropriate

**During size-up (risk assessment)**

- Approach from upwind of the spill or release
- Begin monitoring at a distance where no contamination is expected
- Monitor for oxygen first, then flammable/explosive limits and toxic substances
- Continue to take readings as the spill or release is approached
- Take readings at ground level, a few feet from the ground, and higher in the air
- For confined space, take readings at the entry and throughout a confined space. Do not allow entry if there is inadequate oxygen or an explosive or toxic atmosphere
- Leave the area immediately if readings indicate that PPE is inadequate, or the PPE has been damaged.



**During emergency response actions**

- Continuously monitor all areas near the source of the spill where response activities are occurring; conditions can change rapidly as ammonia is lighter than air and weather can affect movement of the emission
- Retreat immediately if readings indicate that PPE is inadequate
- Decontaminate the equipment properly

**Post –emergency**

- Recharge power sources
- Replace any damaged or expended parts or send for repair
- Store monitors properly to be ready for any use
- Order any needed disposable sampling supplies or replacement parts

**Note:** Detailed information on air monitoring equipment and procedures must be included in the ERP to ensure adequate training, appropriate use, and proper storage and maintenance of equipment.

## What Can Be Monitored in the Air at an Ammonia Release?

Air monitoring can be used to detect or measure many hazards, including:

1. Oxygen Deficiency/Enrichment
2. Fire and Explosion Hazards
3. Toxic Chemicals
4. Corrosivity

### Oxygen-Deficient/Enriched

#### Oxygen-Deficient

Without an adequate concentration of oxygen in the air, the worker is in an immediately dangerous to life and health (IDLH) atmosphere. Normal breathing air contains 20.9% oxygen. OSHA requires a minimum of 19.5% oxygen to be present; otherwise the atmosphere is considered oxygen-deficient. Confined spaces such as tanks, pits, silos, pipelines, boilers, vaults, and sewers are examples of possible oxygen-deficient work areas. Oxygen levels can be reduced during certain chemical reactions, rusting, or some bacterial action (fermentation). Oxygen-deficient atmospheres may cause a person to feel lethargic and potentially lose consciousness. OSHA requires supplied-air respiratory protection or SCBA in atmospheres below 19.5% oxygen.

#### Oxygen-Enriched

The atmosphere is defined as oxygen-enriched if it contains more than 23.5% oxygen. This situation poses a threat of explosion, especially if flammable materials are present. As a result, special procedures are necessary in the area.

Note: 1% concentration equals 10,000 parts per million (ppm). Oxygen (atmosphere) averages 20.9% or 209,000 ppm; therefore, toxic concentrations of gases or vapors in ppm will not result in a change in oxygen concentration.

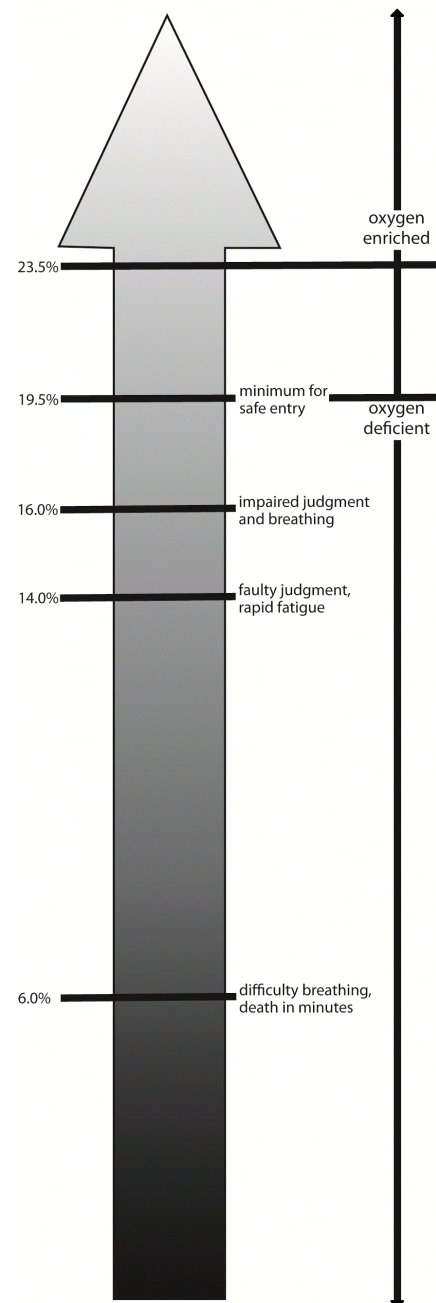

## Fire and Explosion Hazards

Determining whether there is a possibility of fire or explosion is critical. Potentially flammable atmospheres must be monitored frequently in accordance with the Emergency Response Plan (ERP). Protective clothing and respirators which protect the worker from toxic hazards provide little, if any, protection against fire or explosions.

### Explosive Limits

Monitoring results reported as percent can provide information about substances in the air which may potentially cause an explosion. For flammable vapors and dusts, explosive limits have been determined. Two limits are defined below:

**Lower Explosive Limit (LEL)** is the minimum concentration of a flammable gas in the air that can result in ignition. Concentrations below the LEL will not ignite. Below the LEL, the mixture is called “lean.”

**Upper Explosive Limit (UEL)** is the maximum concentration of a flammable gas in the air which can result in ignition. Concentrations above the UEL will not ignite. Above the UEL, the mixture is called “rich.”

NOTE: UEL and LEL are determined in a controlled lab situation. Changes in oxygen concentration will potentially affect the values.

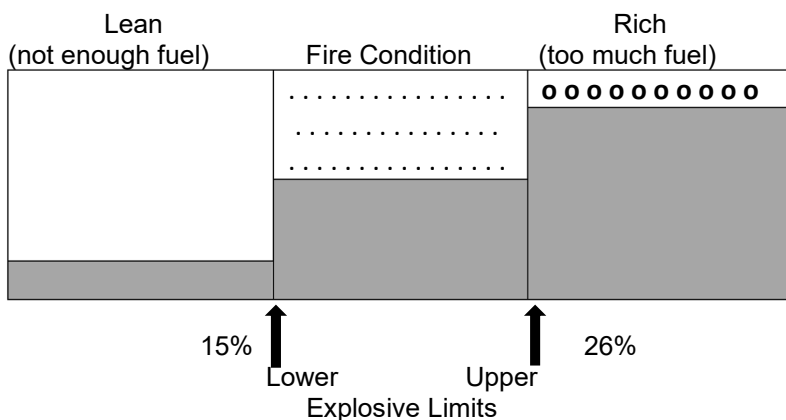

Values LEL and UEL values shown are for ammonia.

NOTE: some sources show UEL=28%.

**Explosive Range** is the concentration of a flammable gas in the air between the LEL and UEL. In this range, the substance will readily ignite if an ignition source is present.

## **Ammonia**

Determining the presence or concentration of ammonia by monitoring the air is limited by the capabilities of the monitoring instrument(s) available.

For immediate results, direct reading instruments are used. These provide information about the presence (detect) and sometimes the concentration (measure) of ammonia. They are generally used near active work or near the breathing zone of responders; this is referred to as area monitoring. Personal badges with direct readout are available for use in the breathing zone. Other personal monitoring of ammonia exposure requires a worker to wear a sampling device to collect a sample that sent to a laboratory to determine the concentration; this is generally not done during an emergency response as immediate knowledge of conditions is required.

## **Corrosivity**

Ammonia is very corrosive (basic) as shown previously on the pH scale (household ammonia). Contact can have adverse health effects, including damage to skin, eyes and the respiratory system. In addition, ammonia can damage monitoring equipment and PPE. This corrosive compound in the air can be detected using pH paper, indicated by a color change.

## **Conducting Monitoring Activities**

---

### **Overall Guidance**

Worksite or municipal management is responsible for selecting equipment appropriate for routine sampling and anticipated emergencies releases of ammonia. Manufacturers provide information about equipment uses and limitations. NIOSH (National Institute of Occupational Safety and Health) and the EPA (Environmental Protection Agency) also provide information about monitoring equipment.

#### **IMPORTANT CAUTION**

Ammonia can degrade or totally ruin a monitoring device. Before planning to use any monitoring device to detect or measure ammonia, discuss possible uses at your plant with technical personnel at the company that supplies your monitors.

Real-time monitoring with direct-reading instruments provides an immediate result and can be performed with a range of devices depending on the information required; the result provides information about the area where the reading was made. If the exposure of a worker is to be evaluated, personal monitoring conducted with a badge will provide real-time data.

Some general considerations when selecting/using monitoring equipment follow:

- The unit should be intrinsically safe. (It will not produce sparks that could trigger an explosion.) Check the label and the manufacturer guide
- Most direct-reading instruments are designed to detect or measure only one contaminant or group of contaminants
- There are no instruments which can sample all toxic substances
- Equipment should be easy to transport and operate in the field under changing conditions and be decontaminated after use as needed
- Instruments should operate properly at temperatures which are anticipated during response activities
- Instrument should be easy to observe/operate while wearing PPE
- Instrument training should be provided through routine, “hands-on” practice
- Many sampling instruments have rechargeable batteries that typically last longer than 8 hours when new and fully charged. Operation may reduce the battery life. Cold temperatures reduce battery charge; never store fully- charged equipment in a cold location prior to use.
- Some equipment can be operated with non-rechargeable batteries, an option when working in remote locations
- For rechargeable batteries, periodically discharge the battery fully and recharge to prevent ‘battery memory’
- Many instruments do not reach the highest readout instantaneously. For chemical sensors, the time to reach 90% of the actual concentration is referred to as  $T_{90}$  and is typically in the range of 15 seconds to 2 minutes. (See manufacturer information)
- Catalytic bead LEL sensors require a minimum oxygen concentration of 10-12% to operate properly

## Sampling Plan or Protocol

A sampling plan is designed to provide representative and accurate information on exposure. A sampling plan includes:

- Procedures for direct-reading sampling during emergencies are detailed in the ERP and include:
  - Equipment needed
  - Frequency, duration and procedures
  - Sampling methods
  - Analytical method (for pH paper and length-of-stain tubes, scale). Benchmark for comparison of result with accepted values
  - Name (and signature)/date of plan developer and any amendments
- Documentation for sampling generally includes:
  - Pre- and post-calibration (if specified in protocol; initials of person doing it)
  - Name/number of sampling/analytical unit; notes on method. Person conducting the monitoring
  - Person monitored (if personal monitoring)
  - Equipment ID number
  - Drawings showing location of sample collection
  - Notes regarding activities conducted during sampling
  - Notes regarding work practices and other exposure controls
  - Use of any PPE
  - Any observed problems with the equipment
  - Any deviation from the sampling method
  - Chain of Custody, as appropriate
  - Result (recorded by sampling personnel)
  - Record of transmitting result to affected persons, as appropriate
- A Calibration and Maintenance Logbook will include the following for each device:
  - Description of required calibration and maintenance
  - Date of each calibration/maintenance
  - Results (often as a letter from an external source)
  - Location of Manufacturer Literature for review, as needed

Note: electronic calibrators must be calibrated according to manufacturer recommendations

Sampling personnel must be trained in the collection method(s) and use of all needed equipment and how to recognize problems during sample collection.

For any sample collection, first make sure you have been trained in the methods and the use of the equipment. It is also important to be trained to recognize problems during sample collection and who to alert if you need assistance. Personal monitoring is generally not done as part of response to ammonia releases; ask the facilitator for information if it is needed for your protocol.

Below are several considerations for use of direct-reading instruments during a response.

### **Before sampling**

#### **1. Use multiple instrument types**

Whenever possible, use more than one type of direct-reading instrument. Remember that each type of instrument has different capabilities, so a reading of zero on one instrument could turn out to be an important reading on another instrument.

#### **2. Follow maintenance guidelines**

All equipment is supplied with a recommended maintenance schedule. Follow it. Should any indication of malfunction be noted during routine checks or usage, report it to the safety officer or other designated person.

#### **3. Bump Test and Calibrate**

Check with designated personnel who oversee the equipment to be sure that it has been properly maintained and bump test or calibration performed prior to use. Bump tests are done on-site. Calibration involves exposing the instrument to a series of known concentrations of a compound and documenting or adjusting for the proper response values. It is important that all instruments be calibrated on a regular schedule recommended by the manufacturer and following repair or maintenance. Some direct-reading instruments are compatible with a docking station interface (consult manufacturer's data for more information).

## While sampling

### 1. Be conservative

If the instrument gives an unexpectedly high response, assume that it is correct. If the reading is suspiciously low, assume that there may be an instrument problem.

### 2. A zero reading does not mean clean air

Always remember that a reading of zero does not mean that the air is free of hazards. Some highly toxic materials are not detected by common direct-reading instruments. A reading of “zero” may mean contaminants are present but at levels below the detection capability of the instrument.

### 3. Read even a small response as positive

Any response, even a small one, on a direct-reading instrument should be interpreted as indicating a potentially dangerous situation. It is far safer to assume that if the instrument can detect a chemical, the concentration may be high enough to pose a health threat.

## Sampling Instruments and Tools

---

Uses of some types of instruments and tools for taking samples of air, soil, water and surface contamination are described in this section, specifically:

### Frequently used

- pH Paper
- Oxygen/Combustible Gas/Combination Instruments - combination most used
  - Multi-gas
- Colorimetric tubes
- Personal Monitors and Alarms for Ammonia
- Photoionization Hydrocarbon Detectors

### Other Ammonia Monitors

- Metal Oxide Sensors
- In-place Ammonia Monitors
- Remote-location Ammonia Monitors
- Sulfur Stick
- Colorimetric Badges



Use, readout and notes are shown. These overviews do not replace manufacturer instructions.

**ALWAYS: read and follow the manufacturer instructions carefully**

It is not expected that you will use all these instruments or tools. The facilitator will tailor the discussion to include those that are appropriate for the expected releases, based on the list you contributed to on Day 1 of the program. The remaining information may be a useful resource in the future.

## **Exercise - Monitoring**

---

The facilitator will review several of the instruments described below that may be used during an emergency response. You will demonstrate an ability to use of one or more instruments in an Exercise (see Exercise Manual) and complete the appropriate Performance Checklist(s).

### **pH paper**

When exposed to a chemical, pH paper changes color indicating the level of acidity or alkalinity.

Use:

Measure presence of corrosive substance

Read-out:

Observed color matched to chart

Notes:

- When using the wetted pH paper for corrosive vapor detection, a neutral reading should not give you a sense of security. Other hazards may be present.
- pH paper can be attached to a stick or an extension tool when approaching an unknown environment, such as during hazard assessment.
- Utilize two pieces of pH paper (one wetted and one dry). The wetted paper reacts more quickly than the dry paper especially for low levels of a chemical in the air. The wetted pH paper is used for detecting corrosive vapor and dry is used to dip into liquids.

Tip: pH meters are subject to interferences, so pH paper is preferred

NOTE: The presence of strong oxidizers may change the colors and give false results.

## Oxygen, Combustible Gas Meters and Multi-gas Meters

### Oxygen Meter

Use:

To sample oxygen concentration, particularly near and in confined spaces

Read-out:

- Usually 0%–25% oxygen concentration.
- At greater than 23.5% oxygen, the explosion hazard increases.
- The normal oxygen concentration is 20.9% - any deviation from this is abnormal and should be investigated as to why there is a change.

(Theoretically, a 0.1% decrease in oxygen due to displacement of the air by another chemical is indicative of a concentration of approximately 5,000 ppm of other chemicals –replacing 1/5 of O<sub>2</sub> and 4/5 of N<sub>2</sub>).

- At less than 19.5%, do not enter without an SCBA or SAR.



## Notes:

O<sup>2</sup> sensors

- Need about 2-3 minutes to warm up
- Continuously react with the air
- Contain electrolyte solution
- Typical operating range: -5° to 120°F
- High carbon dioxide levels may affect reading.
- Typically, the meter calibrates for oxygen during each startup.
- Requires maintenance. (Life of sensor is approximately 2 years under normal use.)
- Acid vapors shorten the life of the electrochemical sensor
- Condensation and/or absorption may occur in long probes
- User must be trained
- Affected by temperature and pressure

## Oxygen Sensor (Simplified)

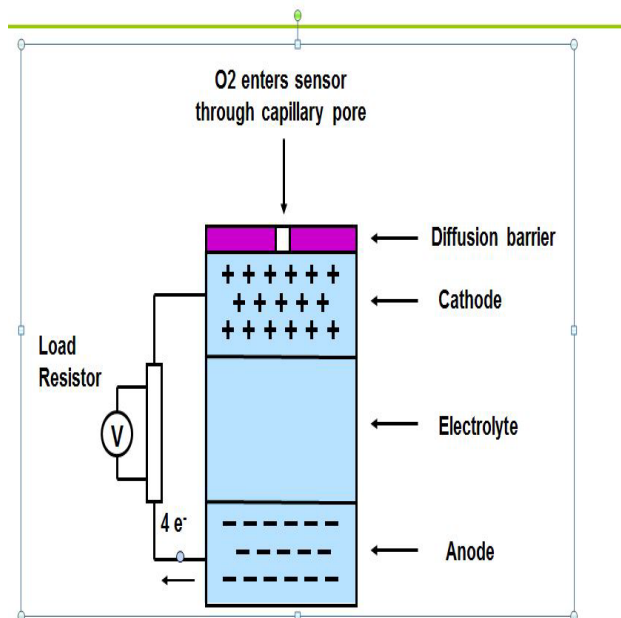

At -5°F to 32°F sensor reaction time slows and eventually will freeze at extreme temperature

Combustible-Gas Indicator (CGI)/ LEL Meter/Explosion Meter

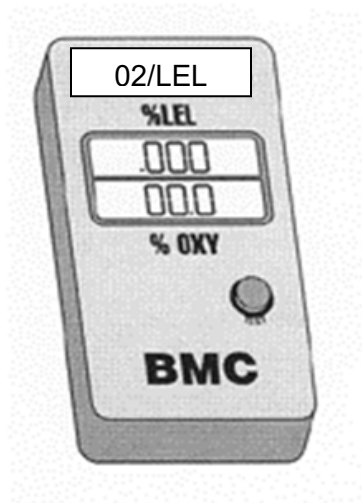
**Use:**

- To measure flammable vapor concentration in percent, particularly near and in confined spaces
- General purpose for most combustible hydrocarbons
- Responds to all combustibles present

**Read-out:**

- % LEL (sometimes referred to as Lower Flammability Limit or LFL).
- A reading above 10% should be considered a potentially explosive atmosphere. (Know what to do when a potentially dangerous reading is noted - for example: leave the area, notify safety officer or incident commander). For added safety, many plans show lower values such as any positive reading, or 5%. The primary reason is that a flammable chemical may be toxic also. A low meter reading, or no reading at all, could still be a dangerous environment.
- Accurate over most of its range

### Monitoring LEL at an Ammonia Release

Not all LEL monitors detect anhydrous ammonia in the needed range. Some do not detect flammable/combustible chemicals with a high flash point.

Consult the procedures manual or the manufacturer instructions. The T<sub>90</sub> response time may be minutes and can fluctuate.

Ammonia for calibration at high concentrations is expensive and unstable, so methane or pentane is used for calibration and then corrected. Some instruments have a built-in correction factor, the readout then being a percent of the true LEL for the ammonia atmosphere.

Example: meter with correction built in

LEL meter readout shows 8% of 15% (the LEL for NH<sub>3</sub>)

$$0.08 \times 15 = 1.2$$

$$1.2 \times 10,000 \text{ ppm} = 12,000 \text{ ppm NH}_3$$

Example: meter with published correction factor

If there is a correction factor from the manufacturer, make a table of reading and corrected reading as part of preplanning. Make a card showing the values and attach it to the meter.

**MAKE TABLE DURING PREPLANNING.  
DO NOT WAIT UNTIL IT IS NEEDED AT A RELEASE.**

#### Notes:

- Requires periodic calibrations. Normal practice is at least every 30 days with a bump test before each use.
- Relatively unaffected by temperature and humidity
- Does not respond the same to all vapors
- Oxygen must be measured first. Many combustible-gas instruments require enough oxygen (consult manufacturer's manual) in order to determine LEL.
- User must be trained.

- Calibration should be checked or done before each use, as per the manufacturer's requirements. Recommendations vary by manufacturer, but before each use is best practice. It is a good practice to check calibration after using an instrument to verify data quality and confirm the sensor was not compromised or injured.
- Nonspecific. Reflects total combustibles present. The specific flammable(s) is not identified. The %LEL is read as if the flammables were the calibration gas. (If a single flammable is present, the manufacturer may provide correction factors.)
- Not recommended for chlorinated hydrocarbons or tetraethyl lead-containing compounds
- Avoid exposing sensors to the following: lead compounds, compounds with sulfur, silicones, phosphates and phosphorous and inhibitors such as hydrogen sulfide and halogenated hydrocarbons.

Example: Calibrated with methane, used in an atmosphere known to only contain pentane

reading of 5%

Pentane correction factor is 2.0

→Actual value is 10% of the pentane LEL

Tip: The common LEL meter is calibrated to read 100% at the LEL of the calibration gas. A small % reading on the meter, while indicating a low risk of fire/explosion at the meter may indicate a potentially toxic concentration. For methane a reading of 5% on the meter indicates a methane concentration of 0.25% or 2,500 ppm.

Important background: LEL sensor technology is typically either catalytic bead on a wire or infrared (IR). The flammable is burned at the bead, increasing the resistance in the wire; the resistance is adjusted for air temperature using a Wheatstone bridge and converted to a reading of LEL. Therefore, oxygen is needed for the meter to function; typically, 10-12% is the minimum required (see manufacturer specs). The IR sensor does not require oxygen for operation.

### Multi-gas Instruments



The meter shown is used to measure oxygen, combustible gases, carbon monoxide and hydrogen sulfide. This is a common combination. Combination real-time monitors for oxygen and flammability (LEL, explosivity, combustibility) are approved for use in flammable environments where the oxygen does not exceed 20.9%, unless tested and approved for use in high-oxygen environments. An alternative is to have sample tubing (probe) to draw the air into the meter that is positioned at a location with acceptable oxygen concentration. The length of the sample tubing will vary for each meter, but typically ranges from 30 to 100 feet. Common problems with drawing samples through tubing include condensation of vapors, and absorption onto the tubing.

When multiple hazards can be measured, these multi-gas instruments may be called 3-4- or 5-gas meters. Ammonia sensors can be added to some of these meters.

Notes:

- The chemical sensors respond to a specific chemical or class of chemicals. Interferences are usually limited (refer to manufacturer literature).

- In addition to temperature, a limitation of these electrochemical sensors is that use in high concentration atmospheres may use up all the reactivity of a cell in a single measurement, rendering the cell useless until there has been time (hours) for the cell to re-stabilize.
- Adding an electrochemical ammonia sensor (usually reading in ppm of <1,000 ppm) may be 'blown away' by an LEL response level in the air at a response and be rendered unusable or require repair.

### **Colorimetric Detector Tubes (also known as length-of-stain tubes)**

A colorimetric detector tube is a glass tube filled with a solid material or gel that has been impregnated with a chemical. When the tube is used, the ends are broken off and the tube is inserted into a bellows or piston pump. An arrow on the tube indicates which end of the tube to insert into the pump orifice. A predetermined volume of air is pulled through the tube, measured by pump strokes. The contaminant of interest reacts with the chemical in the tube. This reaction produces a stain in the tube with a length proportional to the concentration of the contaminant. The concentration scale is read based on manufacturer guidance, including the, length of change and color intensity.

Use:

- Measure gas or vapor concentration
- Identify chemical family of contaminant using manufacturer decision charts and tables.

Read-out:

- Concentration in ppm, mg/m<sup>3</sup> or percent is indicated by color change or length of color stain.

Notes:

- Not very accurate - within 25% of the real value at best
- Pump must be checked for leaks and volume calibrated.
- Tubes have a limited lifetime, so the expiration date on the container should be checked before use.
- User must be trained in reading the scales on the tubes.
- User must follow specific pump-stroke requirements and all other directions.
- Interferences are possible; not very specific.
- May be misread if the sample-taker is color blind
- Specific temperature and humidity ranges shown in directions
- Tube heaters are available from some manufacturers
- Tubes may be marked with number of required pump strokes



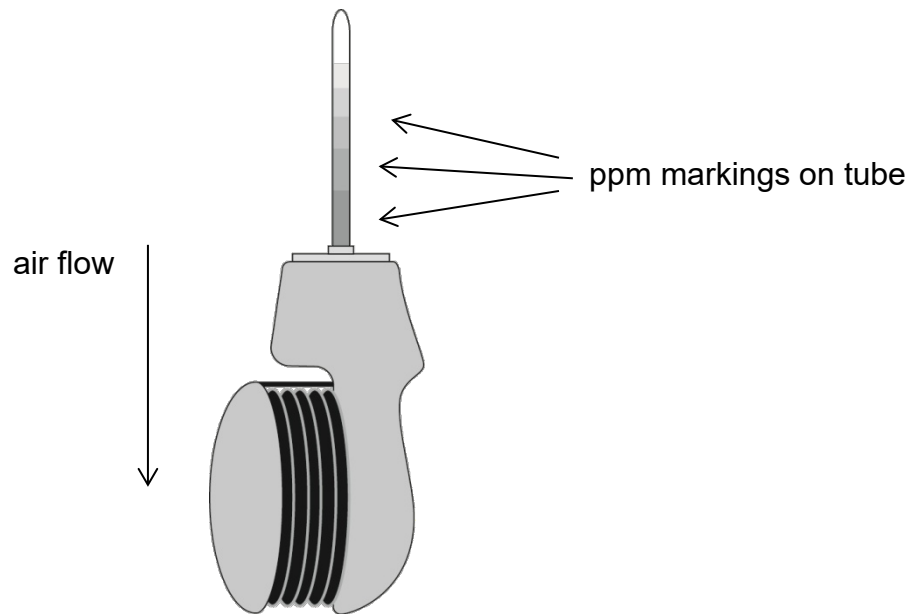

Tip: The Dräger Chip Measurement System (CMS)<sup>®</sup> includes a chip for the chemical of interest. The measurement is complete and digital result read on the screen in 30 seconds to 5 minutes, depending on concentration and chip type. Note that there are not as many chemicals available in the CMS as there are when using single colorimetric tubes.

### Personal Monitors or Alarms for Ammonia

Electrochemical monitors are used to detect a specific level of ammonia and sound an alarm to exit the area. Some provide a measure of the ammonia concentration.



An ammonia meter with two alarms, audible and visible, shown here

A vibration alarm is available on some meters

Use:

- To detect ammonia compared with background levels in any workspace or area
- Alarm level alert workers to a level above which they should not be exposed based on the written Standard Operating Procedure (SOP)

Read-out:

Audible alarm and sometimes visible alarm and/or display of concentration (examples: ppm or %)

Notes:

- Inaccurate readings may be given if there are interferences
- Battery-operated
- Responders must be trained in actions to take if the alarm sounds
- Other compounds that include NH in the chemical formula will contribute to the reading; for example, ammonium hydroxide,  $\text{NH}_4\text{OH}$ , will be measured

### Photoionization Hydrocarbon Detectors (PID)

In PID instruments, ultraviolet radiation is used to ionize (break apart) gas and vapor molecules. The current produced is proportional to the number of ions and is a measure of concentration.

The energy needed to ionize a compound is its characteristic “ionization potential” (IP), expressed in electron volts (eV). The ionization potential for ammonia is 10.2eV.

Use:

- Detect ammonia
- Identify sources of emission

Readout:

- Concentration in ppm

Notes:

- Ability to detect ammonia at ppm-levels
- Can be stand-alone monitor or multi-gas meter
- Can operate in low-oxygen environment
- Detects only those compounds with ionization potentials less than the energy of the lamp
- Response affected by composition of mixed gases
- Only quantifiable if measuring a single, known substance
- Lamps affected by high humidity, high levels of methane and dust
- Cannot separate mixtures
- Other voltage sources may interfere
- Requires calibration (usually with isobutylene)
- User must be trained
- Must know lamp voltage and correction factor (CF)
- Requires regular maintenance



The needed correction factor differs by manufacturer and the eV of the lamp. For example, the correction factor for ammonia using a RAE meter with 10.6 eV lamp is 9.7 and using a BW meter with 10.6 eV lamp is 10.6.

PIDs are often calibrated with isobutylene, which has a correction factor of 1.0. If you

know that a single gas is present in the atmosphere, you multiply the correction factor for that gas by the instrument reading to obtain the true concentration of the chemical.

Example:

A RAE instrument is being used to measure ammonia, with a CF of 9.7

The instrument calibrated with isobutylene reads 100 ppm.

The actual concentration is:

$$100 \times 9.7 = 970 \text{ ppm}$$

NOTE: some PIDs allow the user to insert or select a CF; in this case, the readout is directly in ppm with no additional correction.

NOTE: The  $T_{90}$  of a few seconds for the PID is faster than electrochemical detectors.

## **Other ammonia monitors**

### Metal oxide sensors

There are metal oxide sensors that detect ammonia. These are not widely used at responses but were once used as in-place monitors in ammonia engine rooms as the units had long service life and a high response range. Consult manufacturer's recommendations if you do have one for use, especially about the many interferences that can occur.

### In-place ammonia monitors

Stationary ammonia monitors that read in ppm are often strategically located in engine rooms, air intakes/exhausts or at remote locations to give an early warning of potential ammonia leaks and may be programmed to initiate automatic activation of ventilation, warning lights or shut down of intake air. Remote readouts and or alarm levels give plant personnel an early indication of potential hazard, location/source and can be used to initiate response options according to SOPs in the response plan, without risk to plant personnel.

### Remote-location portable monitors

Monitors that can be set up in remote locations for short periods of time are available.

These portable units can be used at property boundaries and the readout can be viewed at another location such as a command center. This reduces the risk to responders and once set up, the responder can be assigned other duties. These data are valuable to those in communication with community responders and the news media.

### Sulfur stick

A burning sulfur stick is a tool long used by refrigeration technicians to detect ammonia leaks at the source. The burning sulfur reacts with the ammonia to form ammonium sulfate, a white salt that can be seen in the area of a leak.

#### Notes:

- Burning sulfur, also creates sulfur dioxide that is more toxic than ammonia.
- The burning stick will ignite a flammable concentration of ammonia.
- At high concentrations the ammonia in an enclosed room or area appears as a white haze due to reaction with the burning sulfur. This makes it difficult to find the source of the release.

### Colorimetric badge

An ammonia 'badge' that turns color at a specified concentration is available. Because of the uncertainty about accuracy, the result may be more of an indication of exposure. The unit appears to be pH-sensitive, so it may not be specific for ammonia. Ease of use and simplicity are features.

## **Summary - Monitoring**

---

When there is potential for responder or off-site resident exposure to ammonia, monitoring is done to evaluate the level of exposure and provide input to control exposure.

Fire and explosion hazards, corrosivity and oxygen-enriched and oxygen-deficient atmospheres and ammonia in ppm concentrations can be monitored at a release.

There are several ways to describe evaluation of exposures using a variety of sampling instruments and tools:

**Where performed**

**Area monitoring** gives a measurement of the air concentration of ammonia at a specific place and time.

**Personal sampling** shows the concentration of ammonia in the breathing zone (usually on the shoulder) of a responder. Sampling that requires laboratory analysis is generally not done at emergencies, as the information is needed in real-time.

**Information obtained**

**Detect** a hazard means that it is present; detect a hazardous substance means that it is present in an amount greater than the limit of detection.

**Measure** a substance to determine a concentration.

**When results are obtained**

**Direct-reading or real-time instruments** provide a reading of air contamination when you are using the equipment. Direct-reading instruments may be used to detect IDLH conditions, flammable vapors, oxygen, and ammonia.

**Laboratory Analysis.** If laboratory analysis is needed, the results will not be available for some time. This is generally not done during a response.

Personnel using monitoring devices must be trained and use calibrated and maintained equipment. A written sampling plan is developed as part of planning for emergencies; this plan includes procedures to ensure that any equipment that would be needed in an unexpected situation is available and always ready for use.

---

## **Work Practices**

---

Good work practices are vitally important to protect safety and health and the environment. Some work practices conducted by responders are outlined in this section.

Standard operating procedures (SOPs) are worksite- or employer-specific written instructions for work practices that will reduce the risk of exposure to chemical or physical hazards and are a form of administrative control. In order to be effective, SOPs must be prepared in advance, practiced regularly and reviewed at least annually. Implementation of work practices that have been thought out in advance, practiced and reviewed/revised routinely will minimize the risk to responders, the environment and nearby community residents.

### **Learning Objectives**

When you have completed this section, you will be better able to:

- Define the terms standard operating procedure (SOP) and standard operating guide (SOG)
- Describe work practices to reduce risk of injury and further release/contamination during ammonia response operations
- Demonstrate ability to perform a work practice relevant to an ammonia response

## **Types of Hazards**

Physical and safety hazards include a wide range of potential exposures.

Emergency responders face hazards that are unpredictable and may change even during the response. Some of the hazards are listed below:

- Slips, trips, and falls
- Steam
- Confined spaces
- Energy sources
- Ergonomics
- Vehicle operation

Safety is enhanced when responders work in teams, using the ‘buddy system’. The “buddy system” is an administrative (written) control to ensure that work is performed by a pair of responders in sight of one another in order to safeguard one another’s safety and health. A buddy aids in the work, observes the partner for signs of injury or chemical or heat exposure, periodically checks the integrity of the partner’s protective clothing, and notifies the incident commander or others if emergency help is needed. Buddies should work in line-of-sight contact or communication with each other and the incident command post. When wearing protective clothing, workers must make sure that hand signals are recognized, or other communication procedures are in place (Covered later in this program). Any IDLH situation requires communication using a method selected to be safe for the conditions. The buddy system is required for any activity in an IDLH area.

## **Standard Operating Procedures (SOPs)**

### **Standard Operating Guides (SOGs)**

Standard Operating Procedures (SOPs) are carefully planned and detailed work instructions intended to provide emergency responders with necessary guidelines to carry out work tasks safely. Some SOPs for emergencies are adapted from routine plant operations; others provide guidelines for actions that should or should not be taken during an emergency. An SOP includes required training that must be completed prior to conducting the activity.

The ERP includes information about the actual work tasks and activities that you are trained to undertake during or after a release. Each task and the methods to conduct the task is described in an SOP in the ERP.

In this program, we use the term Standard Operating Guide (SOG) as a generic term to describe elements of a safe work practice. An employer-specific or operation-specific work practice is an SOP that includes and expands considerations shown in an SOG.



These SOPs are an administrative control. On the next pages are SOG elements that should be considered in developing an SOP for work practices to reduce injury due to each of the exposures shown above.

### **Slips, Trips, and Falls**

Slips, trips, and falls are common causes of injuries. Examples of situations causing slips, trips, and falls during a hazmat emergency include:

- Slick surfaces
- Steps or debris
- Ice and snow
- Poor-fitting PPE
- Reduced visibility

Prevention is the key to avoiding injuries. Always work in sight of a buddy or in communication. The following reduce the potential for slip/trip/fall injury:

- Where surfaces are wet or slippery--avoid wet areas, move slowly, use available handrails, use footwear with skid-limiting soles
- On uneven surfaces/debris - step high, use walking stick, probe ahead if visibility is poor
- Practice working on ladders in PPE to reduce the hazard of falling during a response

### **Steam**

Steam can cause severe burns. Maintain a safe distance. The steam, or the heat from it, may also react with other materials to complicate the response.

It is possible that what appears to be steam may not actually be steam; seek monitoring or process information when in doubt. Some chemicals may give off toxic clouds that appear steam-like. Also, gases escaping from a pressurized container may look like steam.

### **Confined Spaces**

As an emergency responder, you may be called upon to work in confined spaces to control releases or rescue victims.

NOTE: Entry into a permit-required confined space requires training that is outside the scope of this program. This section is designed to alert you to considerations only.

A confined space generally has three distinct properties which set it apart from other

areas and dramatically increase the risk of exposure to physical or chemical hazards.

Properties of confined spaces:

- Limited ways to get in and out of the space
- Not intended for continuous human occupancy
- Bodily entry is possible, and work can be performed

Some common confined spaces include, but are not limited to:

- Ditches, culverts, and ravines
- Excavations and trenches
- Tank cars
- Vaults
- Sewer systems with manhole entrances
- Vats
- Tanks

Entry into confined spaces poses many dangers. Chemical vapors can accumulate quickly in confined spaces. A confined space might also contain a material that could trap a worker or a moving part that could trap or injure. Entry into confined spaces may block your view of what else is happening around you. Other common confined space hazards involve explosions or fires. Lack of ventilation in a confined space can result in accumulation of toxic or flammable vapors. Something as common as rusting metal or the operation of fuel-powered engines may deplete oxygen. Decaying organic materials such as plants or animals can create hydrogen sulfide gas.

It is important to identify hazards prior to entry; emergency responders must have information from testing of the air throughout the space in order to be adequately protected. The most common confined space injuries are asphyxiation from lack of oxygen, being overcome by very high concentrations of toxic vapors, or rapid skin absorption of organic solvents.

The OSHA Permit-required Confined Space Entry standard (29 CFR 1910.146) requires that each employer survey all confined spaces at a workplace and designate those for which a permit is required.

NOTE: In an emergency, the hazards of a space may change. For example, a ditch not usually containing any hazard could be a catch basin for spilled material. Although not

designated a permit-required confined space by the employer, it must be treated as one until air monitoring shows there is no hazard.

A permit-required confined space (permit space) means a confined space that has one or more of the following characteristics:

- Contains or may contain a hazardous atmosphere
- Contains a material that has the potential for engulfing an entrant
- Has an internal configuration such that an entrant could be trapped or asphyxiated by inwardly converging walls or by a floor which slopes downward and tapers to a smaller cross-section
- Contains any other recognized serious safety or health hazard

Responders performing rescue must be informed of the hazards before entry.

Several steps must be taken to make work safer in confined spaces. Careful advance planning for confined space entry can help minimize the risk of injury. This advance planning must include the following points:

- Identifying confined spaces (Determine which require a permit to enter)
- Developing written SOPs and the permitting process
- Arranging for and strategically locating adequate supplies of air-supplying respirators and protective and life-saving equipment
- Training personnel who must enter permit-required confined spaces to identify and report emergency conditions
- Training personnel how to monitor and properly safeguard the space before and during entry
- Monitoring confined spaces before entry and during work for oxygen deficiency and flammable or toxic atmospheres. Monitoring must be conducted throughout the space, not just at the entry point.
- Complying with the permit and logging system. Under this system, confined space entry is permitted only after all hazards and risks associated with entry have been controlled and/or adequate PPE provided. The permit must be signed by a responsible manager. No personnel can enter the confined space without a signed entry permit. Permits are valid only for a specific date, time, and place.
- Providing appropriate ventilation before and during the work.
- Posting a qualified and trained safety attendant who is ready to aid, if required, outside the confined space entrance *at all times*.

- Training personnel to recognize when the hazards of a confined space may have changed.

Implementing a confined space entry SOP minimizes danger through good work practices.

Examples of a confined space entry log and a confined space entry permit are on the next pages. Other samples can be found in 29 CFR 1910.146, Appendix D.

**Confined-Space Entry Log Personnel and Check-in/Check-out**

LOCATION OF CONFINED SPACE

Building: \_\_\_\_\_

Process or Area: \_\_\_\_\_

Person in Charge: \_\_\_\_\_

DATE OF ENTRY \_\_\_\_ \_\_\_\_

Title: \_\_\_\_\_

Personnel Authorized to Enter Confined Space		Job Title	Work Location in Confined Space		Stand-by Employee(s):	
					1. 2.	
Calibration of Instrumentation		Instrument Readings				
Oxygen Unit	Combust. Gas Unit	Sampling Point Location	Time of Readings	Oxygen Percent	Combust. Gas%LEL	Other Chemicals
Authorized Personnel in Confined Space				Ventilation of Confined Space		
Signature of the Personnel	Time		Provided		Time Period Ventilation	Discharge Air Volume
	Into Space	Out of Space	Yes	No		

## Confined space Entry Permit

Date and time issued: \_\_\_\_\_ Date and time expires: \_\_\_\_\_

Job site/space ID: \_\_\_\_\_ Job supervisor: \_\_\_\_\_

Equipment to be worked on: \_\_\_\_\_ Work to be performed: \_\_\_\_\_

Stand-by personnel: \_\_\_\_\_

1. Atmospheric checks:

Time \_\_\_\_\_

Oxygen \_\_\_\_\_ %

Explosive \_\_\_\_\_ % LFL

Toxic \_\_\_\_\_ PPM

2. Tester's signature: \_\_\_\_\_

3. Source isolation (no entry):

Pumps or lines blinded, disconnected, or blocked .....  N/A  Yes  No

4. Ventilation modification:

Mechanical.....  N/A  Yes  No

Natural ventilation only.....  N/A  Yes  No

5. Atmospheric check after isolation and ventilation:

Oxygen \_\_\_\_\_ %  $\geq$  19.5 %

Explosive \_\_\_\_\_ % LFL  $<$  10 %

Toxic \_\_\_\_\_ PPM  $<$  10 PPM H<sub>2</sub>S

Time \_\_\_\_\_

Tester's signature: \_\_\_\_\_

6. Communication procedures: \_\_\_\_\_

7. Rescue procedures: \_\_\_\_\_

### Confined space Entry Permit, cont.

8. Entry, standby, and back-up persons:

Successfully completed required training?.....  Yes  No

Is it current?.....  Yes  No

9. Equipment:

Direct reading gas monitor tested.....  N/A  Yes  No

Safety harnesses and lifelines for entry and standby persons.....  N/A  Yes  No

Hoisting equipment ..... N/A  Yes  No

Powered communications.....  N/A  Yes  No

SCBAs for entry and standby persons.....  N/A  Yes  No

Protective clothing.....  N/A  Yes  No

All electric equipment listed Class I, Division I,  
Group D, and non-sparking tools.....  N/A  Yes  No

10. Periodic atmospheric tests:

Oxygen \_\_\_\_\_%      Time \_\_\_\_\_      Oxygen \_\_\_\_\_%      Time \_\_\_\_\_

Oxygen \_\_\_\_\_%      Time \_\_\_\_\_      Oxygen \_\_\_\_\_%      Time \_\_\_\_\_

Explosive \_\_\_\_\_%      Time \_\_\_\_\_      Explosive \_\_\_\_\_%      Time \_\_\_\_\_

Explosive \_\_\_\_\_%      Time \_\_\_\_\_      Explosive \_\_\_\_\_%      Time \_\_\_\_\_

Toxic \_\_\_\_\_%      Time \_\_\_\_\_      Toxic \_\_\_\_\_%      Time \_\_\_\_\_

Toxic \_\_\_\_\_%      Time \_\_\_\_\_      Toxic \_\_\_\_\_%      Time \_\_\_\_\_

We have reviewed the work authorized by this permit and the information contained herein. Written instructions and safety procedures have been received and are understood. Entry cannot be approved if any squares are marked in the "No" column. This permit is not valid unless all appropriate items are completed.

Permit prepared by: (Supervisor) \_\_\_\_\_

Approved by: (Unit Supervisor) \_\_\_\_\_

Reviewed by: (CS Operations Personnel) \_\_\_\_\_

This permit to be kept at job site. Return job site copy to Safety Officer following job completion.

Copies: White Original (Safety Office), Yellow (Unit Supervisor), Hard (Job site)

The employer confined space permit program must be in writing and include a description of procedures to:

- Implement measures necessary to prevent unauthorized entry
- Identify/evaluate hazards of permit spaces before employees enter
- Develop and implement the means, procedures and practices necessary for safe operation including but not limited to:
  - Specify acceptable entry conditions
  - Provide each authorized entrant or that employee's authorized representative with opportunity to observe the monitoring or testing of permit space
  - Isolate the permit space
  - Purge/inert/flush/ventilate the permit space as necessary to eliminate or control atmospheric hazards
  - Provide pedestrian, vehicle or other barriers to protect entrants from external hazards
  - Verify that conditions in the permit space are acceptable for entry throughout the duration of an authorized entry
  - Provide equipment for testing and monitoring, ventilating, communication, PPE, lighting, barriers and shielding, equipment for safe access/egress, rescue and emergency and any other needs for safe entry or rescue
  - Evaluate conditions when entry operations are conducted
  - Test conditions before entry is authorized (except in limited, specified situations)
  - Test for oxygen, combustible gases/vapors, toxic gases/vapors in that order
  - Test to determine if acceptable entry conditions are being maintained during the operation
  - Provide each authorized entrant or representative opportunity to observe all testing
  - Reevaluate when there is a request due to belief that prior testing was inadequate
  - Provide the requester with results immediately
  - Provide at least one attendant outside the space throughout the operation (special requirements if multiple entries are monitored, including adequate emergency procedures)



- Designate roles, duties and provide training for all
- Develop and implement procedures to summon rescue/emergency personnel, including:
  - Emergency services to rescued employees
  - Methods to prevent unauthorized employees from attempting rescue
- Develop and implement methods to coordinate operations if multiple employers are represented
- Develop and implement termination procedures at conclusion of entry
- Review operations when there is reason to believe that the program has deficiencies
- Review program (at least annually)

If you provide emergency response that includes the potential for confined space entry at a workplace where you are employed, training is provided by your employer for entry and any specialized task (such as containment) to be conducted in a permit space. If you provide emergency response and may be assigned entry tasks at worksites of multiple employers, your employer must provide training in confined space entry procedures and safety.

Prior to (as part of host-company pre-planning) or upon arrival at a response that requires entry into a permit space, a briefing covering the work and SOP will be provided.

### **Energy sources**

Among the electrical hazards that responders may encounter are downed wires, equipment energized unexpectedly during the emergency response, and risk of sparking due to inadequate or improper grounding and bonding.

Be observant for downed wires and other sources of energy. Do not approach or try to handle downed electrical wires. Report any wires to the Safety Officer or the Incident Commander. Assume the wire is energized unless trained utility specialists have certified that the line is not energized.

Other safe work practices include:

- Using double-insulated tools
- Using pneumatic equipment

- Using ground fault interrupter equipment
- Using cords and equipment with ground prong in good condition

Process or other mechanical equipment may need to be shut down in order to respond to an emergency or control a release. Lockout/tagout (LOTO) procedures are used to ensure that equipment and processes are de-energized and cannot be restarted by someone who is unaware of the activity of another responder.

Implement lockout/tagout before attempting response actions.

Never assume a machine, circuit, or pipe is locked out just because it should be.

**When in doubt, lock it out!**

Common examples of equipment requiring lockout include the following:

- Electrical junction boxes
- Pipes that hold liquid, steam, etc.
- Mechanical equipment with moving parts (grinders, crushers, pulverizers, hydraulics)
- Spring-loaded or -activated devices

The risk of ignition of flammable materials and electrocution is lessened by locking out an electrical circuit. Locking out a steam or hot water pipe may cut off a transmission path for vapors or fumes and prevent burns or accidental contact with the contents of the piping system.

Lock-out requirements are described in 29 CFR 1910.147, The Control of Hazardous Energy (Lock-Out/Tag-Out--LOTO).

Examples of uses of lock-out during an emergency include:

- To reduce power to the area
- To reduce material flow
- As part of confined space entry
- Ventilation systems on or off
- Doors open or closed

The following list shows minimum procedures for LOTO:

- Prepare for shut down: Authorized or affected employee has knowledge of the energy and hazards and means to control the energy.
- Shut down machine or equipment using established procedure
- Isolate the machine or equipment by locating and operating all energy isolating devices
- Affix lockout or tagout devices to each energy isolating device
- Verify isolation prior to initiating any response activity
- Prepare for release from lockout/tagout by inspecting the work area to ensure
  - All nonessential items have been removed
  - Machine or equipment components are operationally intact
  - All employees have been safely positioned or removed from the area
- Remove devices—each by the person who applied it or as specified in SOP
- Inform all affected employees that the lockout or tagout devices have been removed

The employer must review the SOP at least annually to remediate any inadequacies and ensure that the standard is being met. Initial training is required, depending upon the responsibilities of each worker; retraining is required when there is a change in machines, procedures or job assignments or if deficiencies have been identified.

### Example of a Lockout Tag



**LOCKED OUT**

This tag must always be used and completely filled out before it is used.

---

**Do Not Start! Do Not Open! Do Not Close!**  
**Do Not Energize! Do Not Operate!**

1. Employee name \_\_\_\_\_
2. Date lock placed \_\_\_\_\_
3. Time lock placed \_\_\_\_\_
4. Was starter pushed to determine equipment to be worked on did de-energize?  
Yes  No
5. Has the undersigned verified that the correct main breaker has been locked out?  
Yes  No
6. Has the equipment been isolated from other energy systems such as hydraulic or pneumatic which could endanger others? Yes  No

Comments \_\_\_\_\_  
\_\_\_\_\_  
\_\_\_\_\_

If a contract or outside employer is involved in lockout/tagout, the outside and on-site employer must inform each other of their respective procedures and the on-site employer must ensure that all employees understand and comply with the restrictions of the outside employer energy control program.

Failure to follow LOTO procedures may increase the dangers during the response resulting in electrocution, chemical or other burns, or being caught in or crushed by mechanical, pneumatic, or other moving parts.

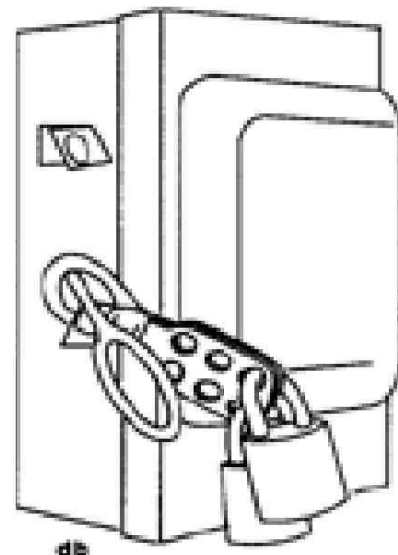

**Locked out, showing multiple locks**

Piping can be a source of static electricity. An evaluation of this potential should be completed during preplanning.

## Ergonomics

The goal of an ergonomics program is to increase the well-being of the worker and make the workplace safer by fitting the job to the worker.

During a hazmat emergency response, unusual postures, lifting, confined space entry and tasks on ladders, unstable or slippery work surfaces add stresses to the body. These stresses may be increased while wearing PPE. Work practice controls include working in teams to reduce carry loads, observation/input from a buddy and a focus on routine practices such as maintaining erect posture, avoiding slippery surfaces and using handholds to reduce the potential for a strain injury.

A reminder: Hurrying may result in delays in the response and injury.

OSHA currently has voluntary guidelines to control ergonomics exposures in some workplaces but not for emergency response. NIOSH has no specific guidance for responders; however publications for the construction industry include several examples of good work practices for material handling that might be adapted (<http://www.cdc.gov/niosh/docs/2013-111/>, <http://www.cdc.gov/niosh/docs/2007-122/>).

## Vehicle Operation

Training in the operation of powered equipment and vehicles used during a response is required before a responder is assigned. Experienced operators need to become familiar with the differences in driving and operating their equipment when wearing Level A, B, or C personal protective equipment due to motion and visibility restrictions. Also, special rules of operation may be in effect during an emergency and should be part of pre-planning.

The following items should be part of an SOP describing use of equipment in an emergency:

- Whenever the equipment is parked, the parking brake must be set
- Do not leave any unattended unit running
- Prevent potential carbon monoxide hazards by minimizing exhaust in closed areas
- Equipment parked on inclines must have wheels chocked and parking brake set
- Equipment used only during emergencies must be routinely inspected
- Breathing air cylinders must be positioned to prevent valve and regulator damage during operation
- Cylinders must be securely attached to equipment
- All equipment taken into the Hot Zone (contaminated area) must remain in that

zone until decontaminated

Equipment operators working in Level B must be able to connect to an air system without the use of the 5-minute escape system. This requirement may be met by:

- Using a longer-duration, NIOSH-approved SCBA unit for entry and egress, modified to fit the vehicle.
- Having the operator park the equipment at the edge of the Hot Zone and go through decontamination and enter the support area. Long decontamination procedures may require an airline hookup in the decontamination area.
- Using an airline from the support area to go to a piece of heavy equipment in the work area, then switching the airline to a supply on the equipment.

An assistant will be required to assist with the airline.

An effective communication system for the response will reduce hazards due to vehicle operation.

All vehicles should be checked periodically to ensure that the following parts, equipment, and accessories are in safe operating condition and free of apparent damage that could cause failure while in use:

- Service brakes (including trailer brake connection, fluid level, etc.)
- Parking system (hand brake)
- Emergency stopping system (brakes)
- Tires
- Horn
- Steering mechanism
- Coupling device
- Seat belts
- Operating controls
- Safety devices (back-up alarms, fire extinguisher, mirrors, etc.)
- Lights, reflectors
- Windshield wipers
- Defrosters
- Hydraulics

All defects must be corrected before the vehicle is returned to service.

When operating vehicles equipped with the Roll-Over Protection System (ROPS), personnel must wear seat belts for the system to be effective. When leaving a machine,

operators should step to the ground instead of jumping from the equipment, because PPE may pose additional hazards. Blades, buckets, or other similar devices should be lowered to the ground and the engine shut down before leaving the equipment. Because the contaminant level may rise suddenly, operators must be prepared to shut down and immediately leave the area when signaled to do so. Equipment should be operated upwind from the emergency whenever possible.

Moving equipment can pose a struck-by hazard. Approaches to avoid a struck-by accident include:

- Secure area and prohibit traffic
- Stay alert to your surroundings
- Listen for vehicle back-up alarms/horns or other alarms
- Assign a spotter to communicate with the responders and equipment operator

## **Actions to Stop or Divert a Release**

---

The potential hazards described above add to the stress of stopping or diverting a release. The work activities needed to control releases must be described in SOPs and practiced. These may be very site-specific. For example, many ammonia leaks occur at valves or joints in piping so having the tools, PPE and skills necessary to approach the point of emission and stop the leak is an important goal to keep production going, limit loss of ammonia and protect responders, workers and residents. Efforts to limit the spread of ammonia into sewers or drains is frequently described in an SOP.

**Work Safely**

Know the SOP for your task

Practice

Work with a buddy

Be alert

Work with wind at your back if possible

Stay in line-of-vision or in communication

When an SOP can be improved, work to assure completion

**Exercise – Work Practices**

---

Your facilitator will select appropriate work practice exercises, tailored to the types of actions you will be assigned. Working in small groups to complete the exercise and then each participant will complete a Performance Checklist to document training. (See Exercise Manual)

**Summary – Work Practices**

---

Hazards can be minimized with the development, practice, use and critique of work practices, often referred to as Standard Operating Procedures (SOPs). The content of some SOPs is shown in OSHA standards (for example, LOTO, 29 CFR 1910.147). Other SOPs to reduce potential exposure to an injury can be adapted from other sources (for example, NIOSH ergonomics guidance). All work practices are specific for the workplace and should be reviewed at least annually or as processes change, or to include 'lessons learned' during practice drills or from a response action identified during termination activities.



## **DECONTAMINATION**

---

Decontamination (decon) is the process of removing or neutralizing contaminants from PPE, tools and other equipment, surfaces and supplies used during the ammonia response. The decontamination standard operating procedure (SOP) describes the methods and procedures. Decon for ammonia does not require all the usual stations for many hazmat responses, but the standard stations may be used if decon is conducted by the local fire department or outside contractor as that is the SOP they have practiced.

### **Learning Objectives**

---

When you have completed this section, you will be better able to:

- Identify the importance of pre-planning for decontamination
- Identify the activities conducted in each zone
- Recognize considerations for establishing each work zone
- Identify basic decontamination methods used at an ammonia response
- Demonstrate ability to set up a decon line

## **Introduction**

---

Decontamination (decon) is the process of removing and/or neutralizing contaminants from PPE, personnel and equipment to prevent exposure that may cause a health effect to the responder or others or affect the integrity of the PPE/equipment during storage. If decon cannot be accomplished, then proper disposal is required. The need for and methods and procedures to accomplish decon is detailed in the decon SOP in the ERP.

## **Pre-Planning for Decontamination**

---

Decontamination is the process of removing and/or neutralizing contaminants that may have accumulated on PPE and equipment. Proper decontamination or replacement of protective clothing or equipment is critical in controlling hazards and ensuring the health and safety of responders. The plan for decontamination is documented in the employer's emergency response plan (ERP) as required in 29 CFR 1910.120(q) (2)(vii); this detailed plan is developed and practiced, communicated to outside responders and other workers and implemented before responders or equipment enter the hazmat area.

The plan must be monitored by the incident commander or a designee.

Decontamination plans include the following:

- A description of the location and layout of potential decontamination stations for the response
- A list of the decontamination equipment needed for the possible hazards (for example, water for removal and brushes for scrubbing)
- The appropriate PPE for persons assisting with decontamination.
- Specific procedures for decontamination of substances that may be encountered during the response
- Methods and procedures for preventing contamination of clean areas
- Methods and procedures for minimizing contact with contaminants during removal of PPE
- Safe disposal methods for clothing and equipment that are not completely decontaminated
- Revisions whenever the type of personal protective clothing or equipment changes, the conditions change, or the hazards are reassessed based on new information

If commercial laundries or cleaning establishments receive contaminated clothing or equipment, they must be informed of potential harmful effects of exposure to any remaining contaminant.

Where the decontamination procedure specifies use of regular showers and change rooms outside of a contaminated area, they must be provided according to the

requirements of 29 CFR 1910.141. If water cannot be used due to temperature conditions, other effective cleansing means must be provided and used.

Following the plan results in these outcomes:

- Protects responders from exposure to hazardous substances and contaminated equipment
- Prevents continued permeation of the hazardous substance into PPE
- Limits transfer of harmful substances to employees in clean areas
- Prevents the mixing of incompatible substances during decon
- Prevents the transfer of contaminants outside the response area
- Ensures routine critique and revision as necessary

The following examples illustrate situations when decontamination should be utilized:

- When PPE has been used in areas of possible contamination
- Before responders go from a “dirty” to “clean” work area
- Before responders, eat or drink, smoke, or use restroom facilities
- Before contaminated emergency response vehicles or equipment leave the response area
- Before process equipment in the area of the response is put back into service

## **Limiting Contamination**

---

The primary goal is to avoid employee contamination by minimizing contact with hazardous materials.

Specific procedures are used to prevent personal contamination.

For example, procedures during donning PPE will minimize the potential for contact with a hazardous material, such as:

- Inspecting PPE before each use to ensure it is in proper condition
- Closing zippers, buttons, and snaps fully
- Tucking gloves over or under the sleeves as specified in the SOP for any task where gloves and sleeves are overlaid to prevent contaminants entering between the two
- Wearing a third pair of tough outer gloves
- Putting legs of outer clothing over boot tops
- Place any head covering that is not attached to a suit outside the collar

- Taping all junctures with tape with adhesive compatible with suit materials to help prevent contaminants from entering inside gloves, boots and zippers

Other precautionary measures can help reduce the amount of contamination during response activities, such as:

- Using work practices that minimize contact with hazardous substances
- Avoiding puddles, plumes, or areas of obvious contamination
- Minimizing contact with surfaces potentially contaminated with hazardous substances
- Using remote devices such as robots and cameras
- Covering monitoring and sampling instruments (plastic bags with openings for sensors or intake ports), following manufacturer recommendations for preventing contamination to instruments and makes it easier to decontaminate instruments after use
- Covering equipment and tools with a coating which can be stripped away as one step in decontamination
- Wearing disposable outer garments
- Using disposable equipment where appropriate

The spread of contamination after the response is limited by actions including:

- Using methods to verify effectiveness of decon
- Decon containers and supplies that will be re-stowed
- Proper disposal of all wastes—tools, disposables, solutions

## **Work Zones**

---

Zones are established to limit movement of contamination and contaminated materials. Three work zones are:

- The **Hot Zone**, or **Exclusion Zone**, which is the area of highest contamination.
- The **Warm Zone**, or **Contamination Reduction Zone (CRZ)**, which is the area surrounding the hot zone, where decontamination occurs.
- The **Cold Zone**, or **Support Zone**, which is the area free of contamination, where support activities occur.

These zones are shown in the figure below:

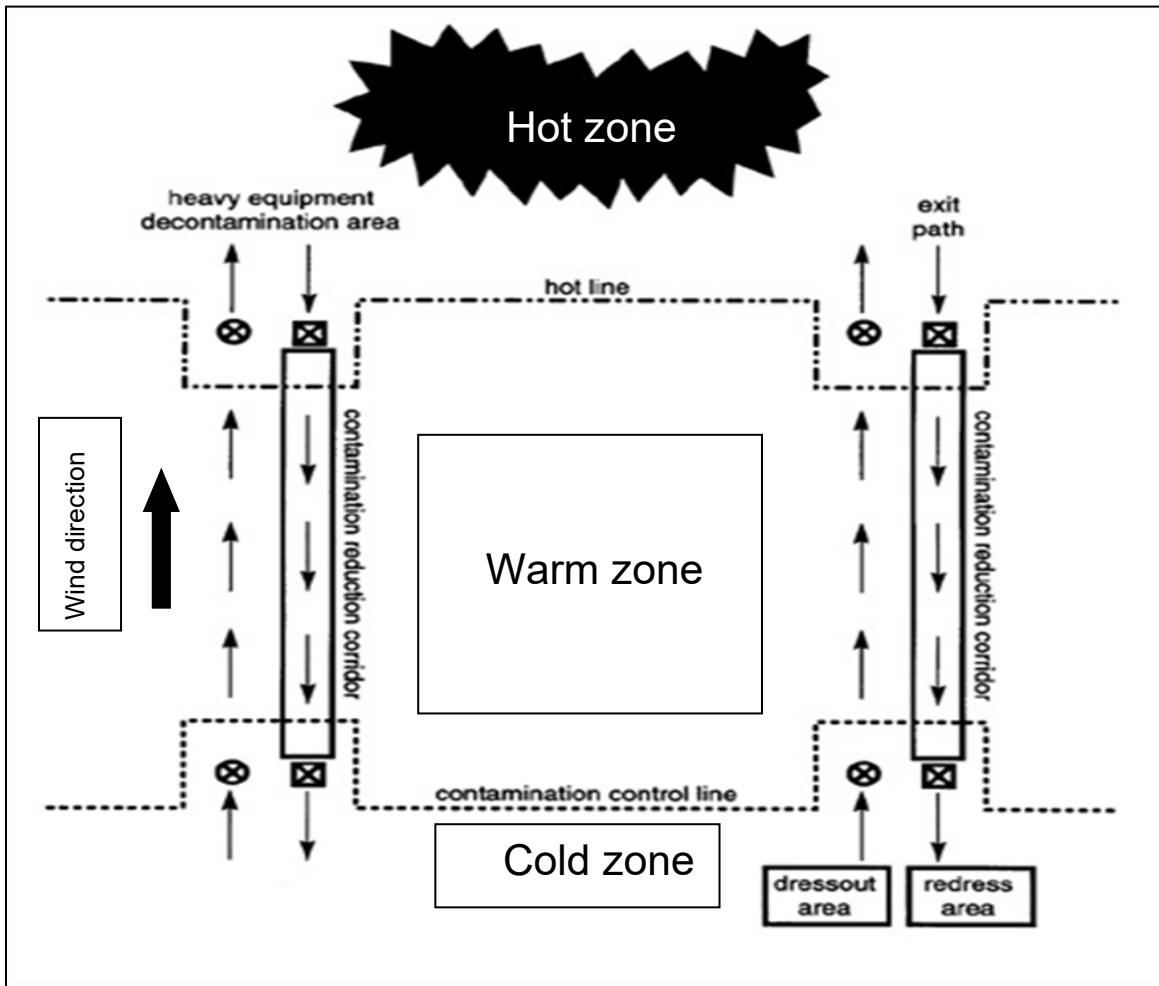

## Primary Activities in Each Work Zone

---

Different activities are performed by authorized employees in each zone. Movement of personnel and equipment between zones occurs at specific access control points.

**Hot Zone/Exclusion Zone/Danger Zone:** This zone refers to the area where the hazard is being assessed or controlled. Primary activities in this zone include emergency response hazard assessment (mapping, photographing and sampling) and spill containment and control.

The size of the zone is determined by the characteristics of the area where the hazmat emergency has occurred and access points. The “Hot line” is the outer boundary and should be clearly marked with hazard tape, lines, signs, or ropes. Further subdivision of the area may be necessary depending on the hazard and activities being conducted. The level of PPE necessary will be determined by the hazard, monitoring results, and the ERP. It will usually be Level A or Level B; Level C may be used when the hazard is identified, and the situation meets the criteria shown in the ERP.

**Warm Zone/Contamination Reduction Zone/Decontamination Zone:**

Decontamination takes place in a designated area called the Contamination Reduction Zone (CRZ) and is the primary activity in the Warm Zone. The boundary of this zone is called the Contamination Control Line.

The degree of contamination decreases along the CRZ, from the Hot Zone to the Cold Zone. Tools are dropped and clothing and protective gear are removed step-by-step to prevent the transfer of hazardous substances to cleaner areas. PPE for responders in this zone is usually one level lower than that used in the Hot Zone. Depending on the hazard and the ERP, the same level of PPE may be required.

**Cold Zone/Support Zone/Clean Zone:** The Cold Zone is free of known contamination. Here, responders exiting the Hot Zone have removed all PPE. Final determinations should be made here about the effectiveness of the decontamination procedures by visual examination and other methods shown in the ERP.

This zone also contains the administrative and other support functions that keep the response running smoothly.

**Decontamination Line, overview of set-ups:** Decontamination must occur before responders re-enter any clean areas. Decontamination procedures will vary depending on the nature and extent of contamination. Procedures must be specified in the ERP.

The decontamination line is an organized series of workstations arranged in a specific sequence to reduce levels of contamination on personnel, PPE, and equipment until no

contaminant is present. Each procedure is performed at a separate station. The stations are arranged in order of decreasing contamination, preferably in a straight line. All decontamination activities are conducted in the Contamination Reduction Corridor (CRZ).

Outer, more heavily contaminated items such as boots, gloves, and suit should be decontaminated and removed first, followed by the decontamination and removal of inner, less-contaminated items (inner boots and gloves).

The graphics on the following pages show selected, generic decontamination layouts taken from <https://www.osha.gov/SLTC/hazardouswaste/training/decon.html>. Additional layouts are shown in this resource. Each of those shown below is labeled.

Some important observations:

- Each procedure is performed at a separate station. The stations are arranged in order of decreasing contamination, preferably in a straight line
- Tools and equipment are dropped at specified locations
- First, outer more heavily contaminated items such as boots, gloves, and suits are decontaminated and then removed
- Next, inner, less-contaminated clothing (inner boots and gloves) is decontaminated and removed
- Facepieces are removed near the end of the line
- Materials that cannot be decontaminated are discarded

Notes: Complete decontamination of protective clothing may not be possible if the contaminant has permeated into or degraded the CPC; when this occurs, the CPC should be discarded.

As a general guideline, if a team of responders comes to the decontamination area at the same time, the least contaminated individuals should be decontaminated first. Exceptions to this guideline are medical emergencies and responders who are low on air or who have damage to PPE that might result in direct contamination to inner clothing or skin.

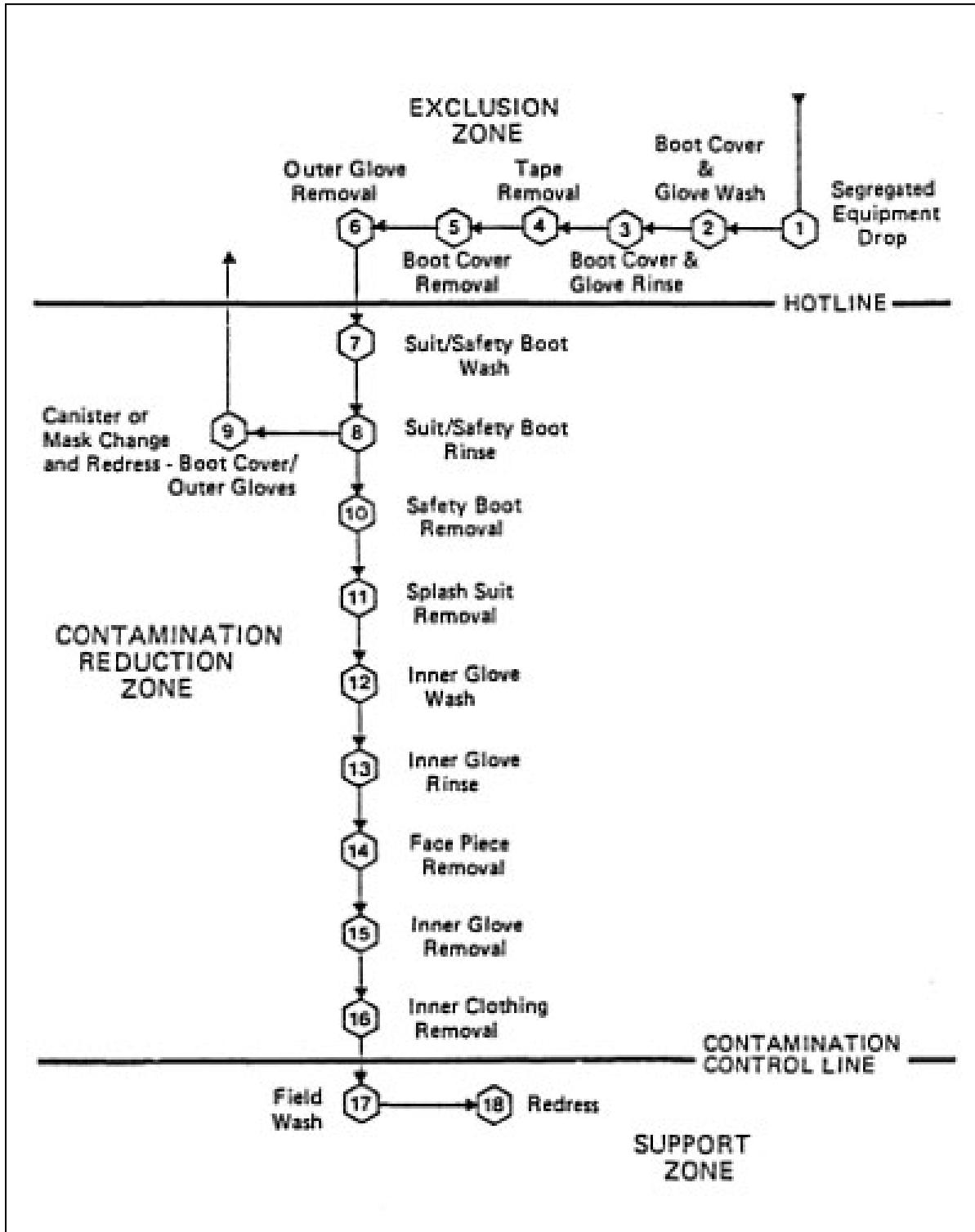

Level C Maximum Decontamination Line Layout



The following diagram shows a typical decon line for an ammonia response.

**Minimum Decontamination Layout Level A, B and C**

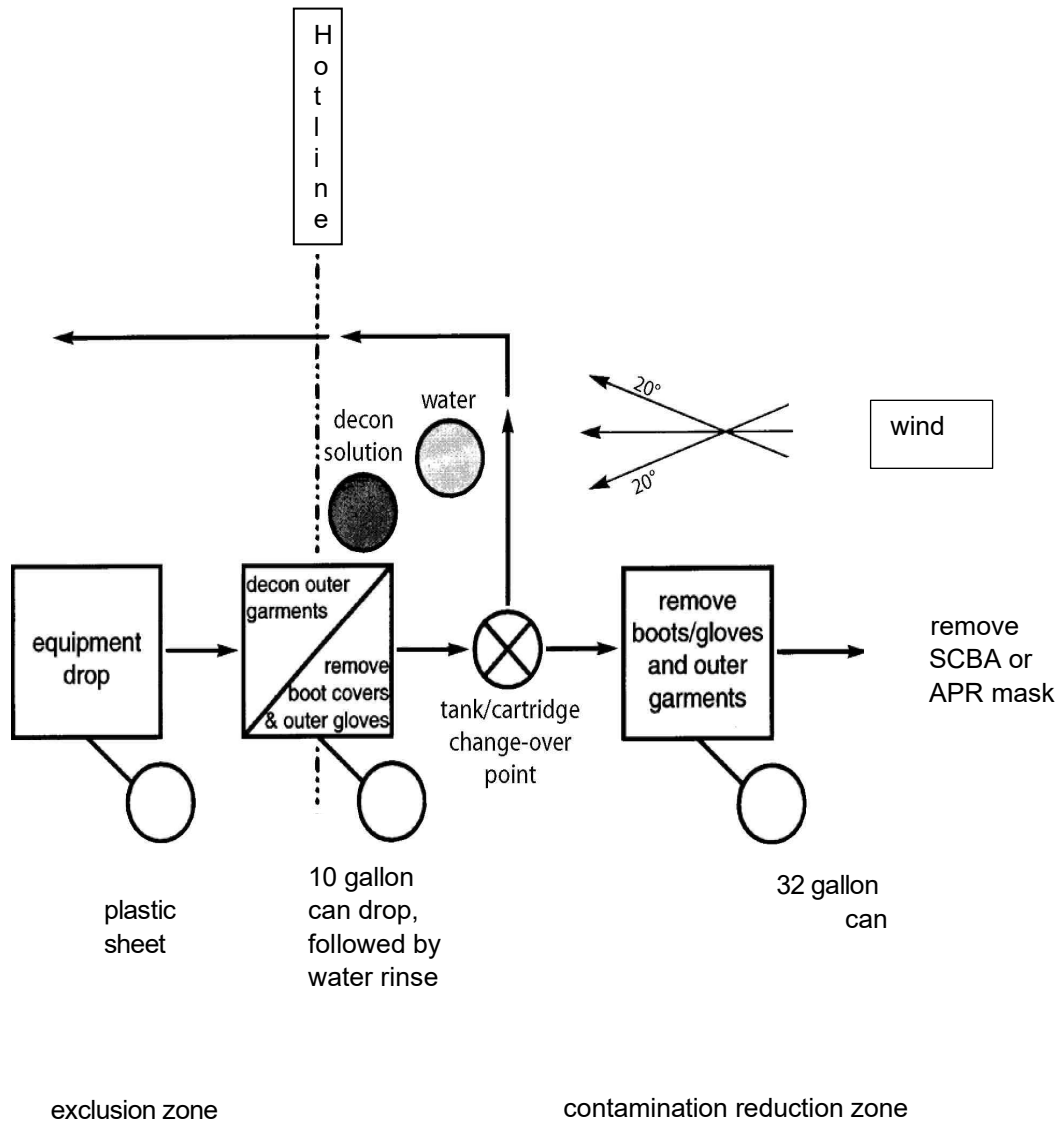

## Ammonia Decontamination Procedures and Follow-up Steps

---

All responders and workers, clothing, equipment, and sample containers leaving contaminated areas must be decontaminated to remove any hazardous materials that may have adhered to them.

Ammonia decontamination can be accomplished by:

- Evaporation to dry
- Rinsing off contaminants
- Combining the Evaporation and Rinsing methods
- Dry methods

The selection of method(s) is based on the work tasks and may be affected by weather conditions and other factors described in the ERP. Manufacturer recommendations for decon methods and materials should be consulted during the process of developing the Decon SOP and the follow-up actions needed to support decon.

### Evaporation

Because of the properties of ammonia, much of the contamination may evaporate before a responder reaches the decon line. However, pools may be trapped in the PPE folds.

### Rinsing off Contaminants

Wet decon may follow evaporation as a decon method. This may be particularly important if there may be pools of ammonia trapped in the folds of PPE.

A soap and water solution is most frequently used to help remove contaminants. The soap may be referred to as a surfactant. The soap is not needed for the ammonia removal but may be helpful if there is dirt contamination on the PPE that requires a mechanical means of removal such as brushing.

Multiple rinses with clean solutions will remove more contaminants than a single rinse with the same volume of solution. The most common type of ammonia removal is a water rinse with or without soap; regulated pressure or gravity flow may be used for the supply.

When the responders are 'dry' following the response actions it may be possible to use plant facilities for decon, such as a safety shower or locker room shower. This can only be done as specified in the ERP. When this is an option, decon areas and water sources should be marked on laminated maps posted throughout the facility.

If water decon is to be used, planning will include a method to catch all decon solutions. If contamination is very low, it may be possible to set up decon near a drain that goes to the plant wastewater treatment plant; however, if the concentration is higher this may alter plant processes. This must be carefully considered with plant personnel—in advance—and described in the ERP.

#### Notes

Volatile liquid contaminants such as ammonia can be removed from protective clothing or equipment by evaporation followed by a water rinse. Care must be taken to prevent inhalation of the evaporating chemicals.

Dust and vapors/liquid trapped in folds or seams of PPE can be removed with water or a liquid rinse.

### **Dry decon**

A dry decon is a common consideration in ammonia emergencies where responder exposures are measured to be low or the activity has been conducted outside, as ammonia will evaporate quickly. However, it is important to always have a 'plan B' for water decon described above, especially if there is a victim involved.

Dry decon will not be appropriate if the responders' PPE is wet due to rain, water spray or work in wet areas or the responders have been in an area of high ammonia concentrations. In this case the caustic solution of ammonia and water will be removed by wet decon.

### **Decontamination of Equipment and Breathing Apparatus**

Decontamination of equipment is an important method of controlling the spread of hazardous substances and preventing deterioration of the equipment.

- **Monitors** - If monitoring equipment becomes contaminated, it will require special cleaning. The manufacturer or local/regional government agencies can provide information on proper decontamination methods.
- **Tools** - Metal tools should be cleaned, as appropriate by water rinse. EPA regional laboratories may be consulted for specific methods to decontaminate tools. Wooden tools and tools with wooden handles are difficult to decontaminate because they absorb chemicals. When in doubt, discard any tools that may have absorbed ammonia.

**Respirators and SCBAs** - Certain parts of contaminated respirators and SCBAs, such as the harness assembly and leather or fabric components are difficult to decontaminate. If grossly contaminated, they may be discarded rather than implement costly decon. Rubber components can be soaked in soap and water and scrubbed with a brush depending on the contaminant. All parts of the respirator should be decontaminated and maintained according to manufacturer recommendations. Persons responsible for decontaminating respirators should be thoroughly trained in respirator cleaning and inspection.

### **Evaluating the Effectiveness of Decontamination**

Decontamination methods vary in effectiveness and should be assessed during development of the ERP and when new information is received. If contamination is not being removed or is penetrating protective clothing, the decontamination program must be revised. The following method may be useful in assessing the effectiveness of decontamination.

**Testing:** An ammonia monitor and pH paper can be used to evaluate the effectiveness of decon. Follow the SOP included in the ERP.

### **Containing Contaminated Solutions**

Contaminated wash and rinse solutions along the decon line are contained by using step-in containers to hold spent solutions, or other methods of containment. Rinse solutions from PPE or tool decon must also be contained for disposal.

### **Disposal of Contaminated Materials**

All contaminated material, equipment and spent solutions must be segregated and placed in properly selected and labeled drums/containers for disposal according to local, state, and federal regulations.

## **Other Considerations**

---

### **Protecting those on the Decontamination Line**

Personnel stationed in the warm zone to decontaminate those who have performed duties in the hot zone must be protected from exposure. Those at the beginning of the line (closest to the Hot Zone) may require more protection from contaminants than those assigned to the last station in the decontamination line. These workers on the decontamination line generally wear protection one level below that of personnel in the Hot Zone. For example, if Level B is worn in the Hot Zone, Level C may be appropriate for those in the CRZ. However, in some cases, decontamination personnel use the same

level of PPE as is worn in the Hot Zone. The selection of the PPE for the decon line workers is detailed in the ERP. Decon line personnel go through appropriate decon after everyone from the hot zone has been deconned.

NOTE: Assigned decon workers are often dressed in Level C, as very little ammonia gas remains on the PPE when responders enter the line.

### **General Safety Precautions for Decontamination**

- Decontamination solutions must be compatible with the hazardous substances being removed to prevent a reaction which could produce an explosion, heat, or toxic products
- Include adequate personnel to help each person through the line
- If plastic sheeting is used or other slippery surfaces may be encountered, “gripper” decals or other material should be used to reduce the likelihood of slips
- Provide handholds while boots are being washed or boot covers removed
- Provide stools (not wooden unless they will be disposed of after the response) for personnel to sit on at stations where boots or suits are removed
- Shower and change rooms provided outside of a contaminated area must meet the requirements of OSHA 29 CFR 1910.141
- Unauthorized employees must not remove contaminated protective clothing or equipment from the decon line areas to avoid the spread of contamination

### **Ammonia-specific Precautions for Decontamination**

- If a responder or victim comes to the decon area heavily contaminated with liquid ammonia, the addition of water will result in a spike of ammonia gas and ammonium hydroxide contaminated water. If possible, allow the ammonia to vaporize from the PPE; maintain unprotected workers out of the area and use wind direction to limit exposure.
- Anyone that has been contacted by liquid ammonia should be FIRST washed with water to promote thawing, and only when thawed is the clothing or PPE removed; when in doubt, leave the clothing in place and continue to rinse with water. This will minimize tissue damage and chance of infection.

## Decontamination and Emergency Medical Issues

People contaminated with hazardous materials may be injured. This combination poses a serious challenge to the emergency response personnel.

When there are injuries, a separate decon line may be put in place for victims.

**Which Comes First: Decon or Treatment?:** The approach taken requires preplanning and depends on the hazardous material, type of injury, and preparation to prevent spreading contamination.

Some basic areas that must be addressed in the ERP are listed below:

### Hazard Assessment

- Overview of the scene
- Response plan
- Rescue plan

### Patient Rescue Procedures

- HAZMAT team required
- PPE required

### Patient Assessment

- Infectious agents, universal precautions
- Airway/CPR
- Respiratory support
- Bleeding/blood precautions

### Patient Decontamination

- Removal from Hot Zone
- Special equipment
- Protect privacy

The Incident Commander will direct management of any injured personnel based on the hazards and patient assessment.

## **Demonstration - Victim Decon (optional)**

---

Using a training mannequin, several victim decontamination procedures will be demonstrated by the facilitator for discussion.

## **Exercise – Setting up a Decon Line**

---

For a scenario provided by the facilitator, you will set up a decon line for an ammonia response. (See Exercise Manual)

## **Summary - Decontamination**

---

Exposure to the responders during doffing of PPE and the spread of hazardous materials is prevented using decon methods. The HAZWOPER standard requires proper procedures to be developed for hazmat emergency response activities. Precautions should be taken to prevent contamination of personnel and expensive equipment, such as exposure monitors and powered equipment.

During the implementation of the response, work zones are established to control the spread of contaminants. There are three zones:

- The **Hot Zone or Exclusion Zone** is the area immediately contaminated by the spill or release. Only personnel in adequate PPE should be in this zone.
- The **Warm Zone or Contamination Reduction Zone (CRZ)** is the area surrounding the hot zone where decontamination occurs.
- The **Cold Zone or Support Zone** is the area where there is no contamination and support activities occur.

The decontamination line is:

- An organized series of procedures, performed in a specific sequence
- Used to reduce levels of contamination on personnel, PPE, and equipment
- In operation until no contamination is present, assessed by the criteria in the ERP

Methods to decontaminate personnel, PPE, and equipment will vary depending on the hazardous materials at the response site. Basic methods include:

- Evaporation
- Rinsing off
- Combining the Evaporation and Rinsing methods—most used for ammonia
- Dry methods

Stations are arranged in order of decreasing contamination, preferably in a straight line. Decontamination activities are conducted in the Contamination Reduction Zone (CRZ).

All personnel working the decon line must be decontaminated before leaving the CRZ.

All decon supplies and equipment must be decontaminated or disposed of properly. All rinse solutions must be contained and disposed of properly.

When decontamination of materials is incomplete or not possible, the materials must be disposed of appropriately.



## **Emergency Response**

---

In the event of an ammonia release, rapid response and mitigation are critical to limit injury to people and damage to property and the environment. This section covers approaches to controlling ammonia releases including Emergency Response Plans (ERP), Incident Command System (ICS), training levels, communication, treatment/first aid, security/control, and termination.

### **Learning Objectives**

---

When you have completed this section, you will be better able to:

- Describe application of the ERP to an ammonia release
- Identify the functions of positions in the Incident Command System (ICS)
- Describe methods to control a release
- Identify a potential ammonia release emergency at your plant

### **When does an ammonia release become an emergency?**

---

Minor ammonia leaks occur in most refrigeration facilities and are easily recognized by awareness-level trained employees and reported for appropriate action.

When a leak becomes an emergency is a function of company policy and the OSHA definition of an emergency. A hazardous materials emergency is a spill or release that

cannot be controlled without outside help. In the OSHA HAZWOPER, “outside help” is defined to mean anyone other than employees working in the immediate area or maintenance personnel (see HAZWOPER). This definition also includes the *threat* of a spill or release; determining the potential of incidents is done as part of the development of a plan.

Follow the SOP of your organization whenever an ammonia spill or release is detected. The determination of emergency will be based on decision logic and local resources. Factors may include volume released and concentration. For example, OSHA defines any IDLH atmosphere as an emergency, so a reading of 300 ppm constitutes an emergency condition; some plant procedures use concentrations of 35 or 50 ppm as evacuation triggers and this may be considered an emergency by plant policy.

Emergency Response Team members should assure that exposure levels or situations at which specific actions are to be taken are clearly defined and known by all company personnel.

## **Emergency Response Plan (ERP)**

---

Response to an ammonia emergency requires a planned, structured approach to minimize exposure and preserve health and property. This is initiated through the Incident Command System, a structure of prescribed roles and responsibilities.

A plan developed prior to an emergency is activated when an emergency occurs. This Emergency Response Plan is a detailed, specific set of procedures or SOPs to be followed by trained responders, under the direction of an Incident Commander.

OSHA 29 CFR 1910.120(q)(2) is a list of elements that must be included in the ERP:

- Pre-emergency planning and coordination with outside parties
- Personnel roles, lines of authority, training and communication
- Emergency recognition and prevention
- Safe distances and places of refuge
- Site security and control
- Evacuation routes and procedures
- Decontamination
- Emergency medical treatment and First Aid
- Emergency alerting and response procedures
- Critique of response and follow-up
- Personal protective equipment and emergency equipment

Under the PSM standard, an employer must develop an Emergency Action Plan that covers small releases; the employer must also determine as part of emergency planning if the HAZWOPER standard applies (see 29 CFR 1910.119(n)).

Several aspects of each of these parts of an ERP are described below.

**Pre-emergency planning and coordination with outside parties**

The format of the ERP in HAZWOPER is developed to meet the needs of the users but must include the above elements. A regional plan may be adapted; employers may use the format provided by the Integrated Contingency Plan Guidance from the National Response Team

([https://www.osha.gov/pls/oshaweb/owadisp.show\\_document?p\\_table=FEDERAL\\_REGISTER&p\\_id=13550](https://www.osha.gov/pls/oshaweb/owadisp.show_document?p_table=FEDERAL_REGISTER&p_id=13550)). Existing SOPs can be incorporated, such as the Respiratory Protection Program. The ERP may include additional corporate requirements, or sections dictated by local and state governments.

The ERP is an administrative control: a road map to conduct safe work practices to limit injury and damage in an emergency. The ERP must be reviewed periodically. When conditions have changed or new information is available concerning hazards, the ERP must be updated. The ERP must be available for review and copying upon request by employees, their representatives, and personnel from OSHA and other relevant agencies. Many of the topics in the ERP have been covered in previous parts of this training; however, information on additional sections of the ERP follows:

- Potential ammonia release locations and volume are identified in the ERP; this is critical to plan for response activities and identify any needed coordination with outside groups. The ERP includes topography, layout, and usual weather conditions, as well as procedures for reporting incidents to local, state and federal governmental agencies.

Think back to earlier discussions about potential releases at your site and list up to 5 locations

- 1.
- 2.
- 3.
- 4.
- 5.

- The Local Emergency Planning Committee (LEPC) can facilitate development of the ERP and contact with the local fire and emergency personnel. It is essential to communicate clearly with the local fire and emergency groups to ensure that the location of potentially hazardous chemicals known to all groups. There should be preplanning discussions of the role of each group in potential emergencies.
- The ERP includes contact information for any outside party that must be notified. For example, the (State Emergency Response Commission) SERC and LEPC must be contacted if the release is an “Extremely Hazardous Substances” above the reportable quantity. Your facilitator may detail state-specific requirements.
- As part of pre-planning, the procedures used to conduct an initial evaluation of the hazards of the emergency are described. This initial size-up includes information about:
  - Specific locations where releases may occur
  - Volume that could be released
  - Numbers of people at risk of exposure
  - Need for protective equipment
  - Need for back-up personnel
  - Estimated exposure level(s)

## Personnel roles, lines of authority, training and communication

### Personnel roles, lines of authority

The Incident Command System is the overall structure for roles and lines of authority. See <https://training.fema.gov/nims/>

The ICS includes personnel fulfilling a number of different roles. The number of people involved and their roles depend on the types and nature of emergencies that could occur at a response.

Important response activities that are organized under the ICS include:

- Phone calls, to and from the response location
- Overseeing an assembly area
- Chemical Hazard and Risk Assessment
- PPE selection
- Monitoring needs
- Decon
- 2 in, 2 out
- Communication within the emergency response area
- Entry briefing
  - Written instructions
  - Pictures
- Medical needs and follow-up
- Facility control
- Termination

Preplanning, training and practice are required to ensure that each person is prepared for the specific role within the response. Specialized training may be required depending on expected assigned duties.

The organization of the response team is described in detail in the ERP. An example of the structure of a response team follows, using the standard terms in the National Incident Management System (NIMS). This system was promoted after the 9/11 attack where the need for uniform terminology was identified as essential to assure effective communication between parties.

An example of an incident command organizational chart is shown below.

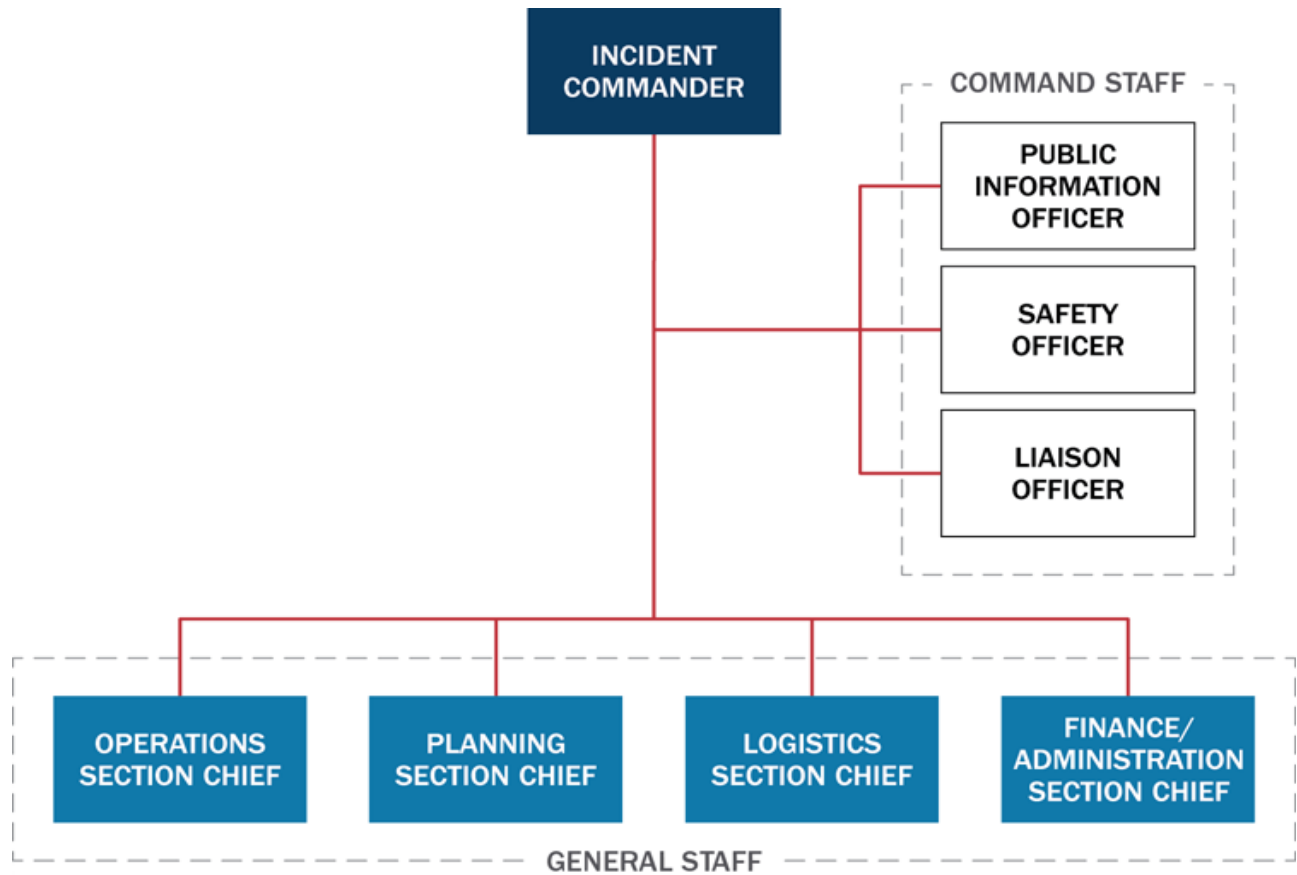

Source: <https://training.fema.gov/nims/>

Key functions of the Incident Commander (person in charge of a response), and response team members in the Command Staff and General Staff are shown below: (reference under figure above)

**Incident Commander** – (The person in charge to oversee all aspects of the response)

Functions:

- Establishes a single Incident Command Post (ICP) for the incident
- Establishes consolidated incident objectives, priorities, and strategic guidance, and updating them every operational period
- Selects a single section chief for each position on the General Staff needed based on current incident priorities
- Establishes a single system for ordering resources
- Approves a consolidated IAP for each operational period
- Establishes procedures for joint decision making and documentation
- Captures lessons learned and best practices

**Command Staff** (see figure above)

### **Public Information Officer (PIO)**

Functions:

- Interface with public, media and/or other agencies with information needs
- Gathers, verifies, coordinates and disseminates information to both internal and external parties
- Monitors the media and other sources and provides information to relevant components of the responders
- Releases accurate information concerning the incident after it is cleared by the Incident Commander

### **Safety Officer**

Functions:

- Reports directly to the Incident Commander
- Monitors incident operations
- Advises the IC on health and safety matters of incident personnel
- Establishes the systems and procedures to assess, communicate and mitigate hazardous environments
  - Developing and maintaining the Safety Plan
  - Coordinating safety efforts
  - Implementing measures to promote safety
- Stops or prevents unsafe acts

**Liaison Officer**

Functions:

- IC's point of contact for representatives from agencies such as fire and law enforcement or other jurisdictions
- Receives input from outside groups to Maintains communication between outside agencies and in-house response
- Point of contact to facilitate coordination of assisting or cooperating agencies or jurisdictions

**General Staff** (see figure above)

**Operations Section**, led by Section Chief

Functions:

- Section Chief appointed by the IC; assigned personnel may change as the incident evolves
- Directing management of tactical activities to achieve objectives established by the IC
- Developing and implementing strategies and tactics to achieve incident objectives
- Section Chief organizes the group to meet the needs, maintain manageable span of control and optimize use of resources
- Supporting Action Plan development for each part of the response

**Planning Section**, led by Section Chief

Functions:

- Collect, evaluate and disseminate incident information to the IC or other personnel
- Prepare status reports, display information, maintain the status of resources
- Facilitate the incident action planning process and prepare the incident Plan sing input from other sections and command staff and IC guidance
- Facilitate incident planning meetings
- Record status of resources and anticipated needs
- Collecting, organizing, displaying and disseminating status information and analyzing the situation as it changes
- Planning for the orderly, safe and efficient demobilization of resources
- Collecting, recording and safeguarding incident documents



**Logistic Section**, led by Section Chief

## Functions:

- Ordering, receiving, storing/housing and processing incident-related resources
- Providing ground transportation during an incident, maintaining and supplying vehicles, keeping vehicles usage records and developing incident traffic plans
- Setting up, maintaining, securing and demobilizing incident facilities
- Determining food and water needs, including ordering food, providing cooking facilities, maintaining food service areas and managing food security and safety (in cooperation with the Safety Officer)
- Maintaining an incident Communications Plan and acquiring, setting up, issuing, maintaining and accounting for communications and IT equipment
- Providing medical services to incident personnel

**Finance/Administration Section**, led by Section Chief

## Functions:

- Tracking costs, analyzing cost data, making estimates and recommending cost savings measures
- Analyzing, reporting and recording financial concerns resulting from property damage, responder injuries or fatalities at the incident
- Managing financial matters concerning leases and vendor contracts
- Managing administrative databases and spreadsheets for analysis and decision making
- Recording time for incident personnel and leased equipment

Note: This chart is adapted as part of pre-planning for the anticipated event and the available personnel. Personnel may be added for other roles, or roles can be combined. For example, on second or third shifts there may be fewer personnel available. The IC may also function as Safety, Liaison and Logistics. Medical support on these shifts may be obtained by contacting local EMS as needed. Roles not assigned by the IC are assumed by the IC. In a response with limited personnel, the IC may conduct the Planning activities and defer some functions such as Finance until later.

An alternative for a small response team is shown below:

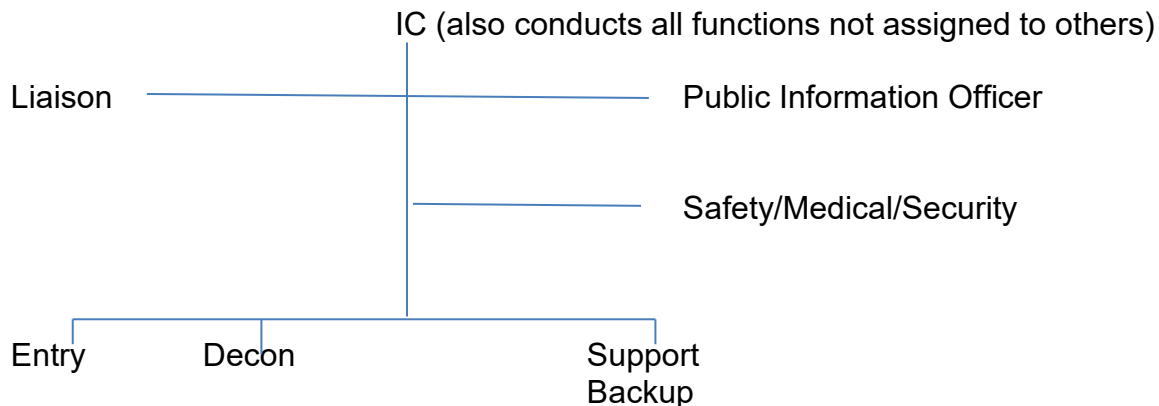

The functions of each position in the ICS must be coordinated and practiced. Each participant requires specialized Incident Command training that is outside the scope of this program. Specific ICS training is required for effective response to an emergency.

**Training**

Response functions can only be filled by trained personnel. Training and practice are required to ensure that each person knows his or her role within the overall ICS. Training differs for those who will contain material, confine it to the source, have overall responsibility or provide a special technical skill such response to a chlorine release. Use of the terminology in NIMS will help assure effective communication with any outside personnel who may be needed during a release.

**Communication**

All personnel will be briefed on the signal that will be sounded in the case of an emergency and/or evacuation and the actions to take. Responders may recognize an unexpected situation that is a new emergency or additional danger and must be aware of methods to alert others.

The “buddy system” is a work practice to help assure that each member of the pair is alert to the safety and health of the other. A buddy provides assistance, observes the partner for signs of chemical or heat exposure, periodically checks the integrity of the partner’s protective clothing, and notifies the command post supervisor or others if emergency help is needed. Buddies should work in line-of-sight contact or communication with each other and the command post supervisor. Workers must make sure that hand signals are understood.

Some common hand signals are shown below:

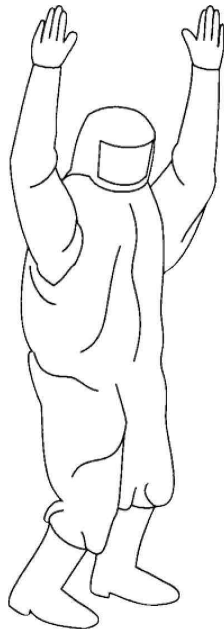
**COMMON HAND SYMBOLS**

In trouble – need help  
getting out of suit

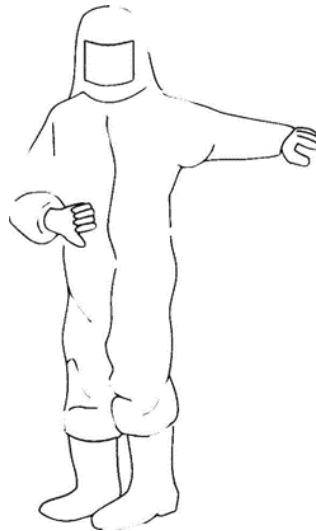

Task cannot be completed  
with remaining air



Out of air

Communication systems are established to alert workers to changing situations, transmit information, and initiate changes in response activities. Communication systems may be internal or external. Internal systems consist of visual cues such as hand signals, lights, flags, and audio cues such as bells, whistles, or compressed-air horns. External systems include telephones or radios; the use of these may be limited due to static electricity or constraints of protective clothing. At some areas where there is a high noise level, specialized ear/hearing protectors with microphones for communication may be used. Employees also must be trained to recognize and use these emergency systems.

**Emergency Recognition and Prevention**

Anyone who may recognize a release that could be an emergency situation must be trained to report needed details to a designated person or sound an alert.

The prevention of an emergency is a major goal of pre-planning - identifying potential events and developing procedures to prevent an occurrence. Examples include preventive maintenance and routine inspections.

## **Safe Distances and Places of Refuge**

The pre-entry briefing will cover locations of refuge. The Incident Commander will determine the safe distances.

## **Site Security and Control**

Security and control are essential functions of the Incident Command System (ICS). Securing the area helps ensure that community members or other bystanders do not enter the facility and become unnecessarily exposed or injured. Also, it ensures only necessary responders are in hazardous areas. The need for multiple personnel to secure a site effectively must be considered during preplanning. You should also consider who will provide that service.

Site control involves assuring that no one enters an area without reason and that proper equipment and training are provided. The response area must be cleared of employees not involved in the response and all entry points controlled. This task can be labor-intensive, depending upon the facility layout, location of the release, and potential release of the material on the ground or in air or water.

Within the ICS, there should be a strategy for working with subcontractors who may be on site. Subcontractors must be aware of what to do in an emergency (meaning of the alerts, safe refuge sites). Your company should define who trains these subcontractors.

## **Evacuation Routes and Procedures**

All responders will be briefed on evacuation routes and procedures.

## **Decontamination (see section on Decon)**

## **Emergency Medical Treatment and First Aid**

On-site personnel who will provide emergency medical treatment or First Aid are listed in the ERP. These personnel require specialized training for those certifications. OSHA requires a person trained as a first responder and patient transport be available at a hazmat emergency response.

Your training provider may be able to offer or direct you to an appropriate Emergency Medical or First Aid course.

## **Emergency Alerting and Response Procedures**

### **Emergency Alerting**

In order to alert all employees to an emergency, the employer must establish an alarm system (OSHA 29 CFR 1910.165).

The alarm system must:

- Notify all employees of an emergency
- Result in work being stopped if necessary
- Lower the background noise to speed communication
- Signal the start of emergency procedures

The alarm system must produce a signal (noise, light, or other) that can be perceived by all employees in the affected area of the response. All alarms must be distinct and recognized as signaling a specific action.

Emergency telephone numbers must be posted in conspicuous locations when telephones are used to report. If another communication system is used, the emergency message shall have priority over all other messages. All manually operated warning systems used to supplement the alarm must be unobstructed, conspicuous, and readily accessible for use. The employer shall ensure that all components of the alarm system are approved for the work site and operating properly. After use (for testing or alarm), the system must be returned to normal operation as soon as possible by the employer. Back-up parts or systems must be available, as appropriate.

The system must be tested at least every two months. If several methods are available to activate the system, a different method must be used for each successive test. The system must always be operational, unless undergoing repairs or maintenance. Any maintenance must be done by trained personnel. Systems installed after January 1, 1981 designed to be supervised must be operated as designed and tested at least annually.

### **Response Procedures**

Response procedures are detailed SOPs in the ERP. Understanding how ammonia will behave when released from a container (component or pipe in the refrigeration system) is crucial to the choice of a control approach.

Review of physical properties:

- Liquid at -28°F, NTP
- Rapidly vaporizes at higher temperatures of NTP as heat is absorbed

- Heat absorption results in cooling of surrounding area
- Very water soluble
- Vapors tend to rise, but this may be affected by weather or moisture

A large liquid release may result in a 'mini refrigeration' cycle, where evaporating ammonia cools the air resulting in re-condensed (liquid) ammonia. Especially in refrigerated areas, liquid ammonia may exist for extended periods of time.

Pre-planned steps in the response such as shut down or isolation should be in writing, practiced in all the needed PPE and periodically reviewed.

## **Video – ‘Shock to the System’**

---

This video provided by the Chemical Safety Board provides details on an investigation of an ammonia refrigerant release. The video and additional details of the release that resulted in 32 hospitalizations and 4 persons being treated in intensive care are shown here: <https://www.csb.gov/videos/shock-to-the-system/>.

---

In a 'best practice' PSM program, potential sources of a leak in the system will be identified and a specified series of steps/actions to be taken will be developed in advance. This reduces the time to research and plan response options. This pre-planning is encouraged at any facility using ammonia as a refrigerant, not just those covered by the PSM standard.

In many facilities refrigeration piping is located on the roof in order to reduce risk to employees. In these instances, careful attention is needed to prevent entry of escaping ammonia into the plant through the make-up air intakes or other openings. Intakes can be designed to automatically shut if remote area monitors detect a release. The use of ventilation is a primary tool inside the plant to reduce employee exposure and downtime. While design and implementation of ventilation plans is outside the scope of this program, it is recommended that the response team members discuss and practice options for ventilating areas where leaks may occur as part of pre-planning.

Ammonia should be blocked from entering drains, unless SOPs specifically allow it. For spill control, conventional products such as oil dry, sawdust or fibers will be of marginal use and may cause some increase in evaporation due to temperature differences and higher surface area contaminated with ammonia. A preferred approach is to have drain plugs, mats or valves in position for use. Confirm that the materials in the plugs and mats are compatible with the low temperature of ammonia. Some valves may be operated to divert the ammonia from going into a municipal or storm water system; a

secondary containment or exposure may result and methods to remediate it must be planned.

Upon entering a sewer or drainage system, ammonia vapor density and water solubility can create some unique situations. Evaporating ammonia may travel 'uphill' in the drainage or the sewer system depending on air flows in the system, potentially resulting in ammonia releases from the system upstream of the facility. Ammonia dissolved in water may contact warm effluent downstream of the facility, releasing ammonia into vents, drains or lift stations remote from the scene of the initial release. Community responders should be made aware of these potential 'off site' exposure sources.

On a large layout map of the facility, identify air flow directions. This will assist in locating the following for a response:

Command post  
Work zones  
Decon

Marking doors, windows or drains that need protection is also recommended.

Methods to isolate areas of the facility will reduce the spread of ammonia and is an important consideration. For example, Department A may have a process that is run at low temperature with ammonia refrigerant. A leak in this process will result in the spread of ammonia to an adjacent hallway and thus into a large bay of the plant that is separated by overhead doors. Closing the doors immediately will limit the spread of ammonia and may be done by designated employees as part of evacuation or electronically from a remote location; actual closure will be confirmed by a responder. Water fogging is a tool used to control or reduce ammonia gas releases. The effectiveness is variable, depending on several factors including the fog pattern (direction, flow), number of patterns, proximity to the release, amount of ammonia gas or vapor in the air, wind speed and air temperature. Overall, effectiveness of fogging out-of-doors is difficult to predict. Consideration of the runoff must be considered carefully in advance; while the ammonium hydroxide concentration may not be harmful, preplanning consideration will help prevent damage to vegetation and water treatment facilities. Water fogging may be useful in a closed space such as a room and may be preferred to ventilation depending on where removed air is vented. If the water is to enter the wastewater treatment stream, preplanning is needed to assure at what concentrations this can be done with safety.

Where ammonium hydroxide is generated, it may be neutralized with a weak acid, preferably in solid form such as a citrate. Spread of the hydroxide can be controlled by conventional diking/blocking spill control products.

**Case Study: Adding water to ammonia to speed evaporation creates hazardous waste**

Water was added to a 10,000-pound spill contained in a room.

The resulting ammonia gas was vented downwind where there were no people.

Resulting ammonium hydroxide solution had a pH of 14.

The solution was deemed hazardous waste.

Solution could not be placed in the municipal sewer system.

Oops.

Preplanning and developing an SOP should have included identifying potential high pH for such a large volume so that plans were in place for handling the waste.

Carbon dioxide gas can be added to control ammonia exposures from a release.



The resulting ammonium carbonate salt is a white powder. Water vapor may need to be added to drive the reaction. Use of this technology is preferred in cold storage areas, due to the low dew point (i.e., moisture content) of these of these spaces where ventilation may cause warming and damage product. However, the added water requires vigilance as frost or icing can increase the risk of slips and falls.

### **Large Release**

In the event of a major release, shut down of the refrigeration system may be the primary option. Location of the control and procedure for this operation (sometimes referred to as the E-STOP) should be a known to the emergency response team (ERT). It may be accomplished remotely by a refrigeration technician or engineer trained in system shut down. Some facilities have developed a systematic, step-by-step process to isolate or shut down the refrigeration process. This will eliminate several possible problems that may arise after hitting the E-STOP.

As part of PSM and as described in company SOP, this overall shut down may not require an IC and ERT response, as it is usually accomplished in the cold zone. If entry into the hot zone is required then the IC system must be in place as described in the ERP.

### **Releases That Do Not Involve System Shut Down**



The most common source of an ammonia leak is a system valve. This can be controlled by tightening the packing nut. If this is unsuccessful, closing the valve upstream of the leak is the next response option. Communication with command is necessary before this operation is initiated to confirm the valve identification and determine the next response activity. Other valves may need to be closed to accomplish isolation due to the refrigeration cycles.

Another option is to close the King Valve while leaving the suction side of the system running to draw as much ammonia as possible back to the receiver. Some older refrigeration systems do not have the capacity to store all the ammonia in the system.

Trapping ammonia in a vessel may create another release potential due to pressure buildup as the ammonia heats. In the event of a power outage or LOTO of the power to an area, it may be necessary to open a solenoid valve to prevent trapping ammonia that will increase the fire and explosion hazard.

Tightening bolts on a leaking flange may reduce or stop a leak.

Escaping ammonia vapors may be re-condensed using a 'sock' put on a leaking pipe and collecting the liquid in a container. By condensing vapors escaping from a vessel, the tank may be cooled to the point where evaporation is greatly reduced. This does not fix the leak, but potential exposures are reduced.

### **Termination (Critique of response and follow-up)**

Much can be learned by reviewing the response activity and conducting appropriate follow-up. These activities include:

- Gathering release data
- Documenting response activities
- Making needed reports to the parent company and/or governmental agencies
- Holding incident critique meetings and making reports
- Evaluating the procedures used and the ERP
- Modifying the ERP
- Checking equipment
- Performing final decontamination and storing equipment
- Restocking PPE and other response equipment
- Reviewing potential human exposures and following up medically when appropriate

The following steps are conducted in termination:

- Debrief

- Reconstruct the response
- Critique (review) the response
- Correct/Fix

Using a structured SOP with forms to document findings and actions will help ensure that all termination requirements are met and completed.

**Personal Protective Equipment and Emergency Equipment** (see PPE and Work Practices)

### **Summary – Emergency Response**

---

Potential spills or releases of ammonia should be anticipated, and safe response requires preparation through pre-planning and practice.

Emergency response actions follow predetermined plans that have specified content in the Emergency Response Plan (ERP).

Use of the Incident Command System supports an organized response, termination and after-action steps.

An alerting system is used to inform everyone of an emergency condition and special communication systems must be in place for responders.

The training required for responders to carry out the response SOPs are detailed in the ERP.

Ammonia release control methods that are developed during pre-planning and detailed in SOPs may include:

- Shutting down the refrigeration system
- Closing valves
- Tightening bolts and fittings
- Controlling the ventilation system
- Blocking drains and sewers
- Water fogging
- Carbon dioxide gas treatment
- Citric acid

## **Tabletop Exercise**

---

Working through a large-scale exercise on a tabletop is a method to think through issues that arise in the course of an 'anticipated' response, without the use of personal protective equipment and full-scale mock-up of the scene.

The facilitator will provide a scenario. Work in small groups to use the information as if you were responding; describe the actions you and the group would take at each step, as the activities unfold. Complete the Performance Checklist. (See Exercise Manual).

### Learning Objective

- Demonstrate active participation in the ICS to implement an Emergency Response Plan through termination (tabletop)

## **Level A or B Simulation with Full Decon Line**

---

Technician-level emergency responders must have the following competencies, certified by the employer:

- Know how to implement an ERP
- Use field survey instruments
- Be able to function within an assigned role in the ICS
- Know how to select and use PPE
- Perform advanced control, containment and/or confinement
- Implement decontamination procedures

You have demonstrated ability to use of field survey instruments, use of levels A, B and C during dressout and performed advanced control, containment and/or confinement work practice techniques and this has been documented with performance checklists. You will continue to practice these skills and document the additional skills. In this simulation, you will function within an assigned role and implement decontamination.

Skill development requires practice!

## **Objectives**

---

When you have completed this exercise, you will be better able to:

- Participate in sizing up a scene
- Contribute to planning a response
- Don/doff a level of protection
- Demonstrate participation in setting up and critiquing a decon line, consistent with the level of protection of the simulation
- Demonstrate an ability to conduct a task required in a technician-level response and provide critique
- Properly dispose of contaminated materials

## **Exercise – Level A or B Simulation with Full Decon**

Working in the buddy system, you will dressout, conduct a task and participate in a full decon, appropriate for either a Level A or Level B response. Throughout the exercise, checklists will be provided to document skills in completing an assigned role and implementing decon. (See Exercise Manual)

Before beginning the simulation, there will be:

- Review of the ERP for training
- Introduction to the Scenario
- Review of relevant SOGs or SOPs
- Opportunity for questions

## **Cleanup and Critique (Termination)**

---

Following any response, there is a need to clean up the area, evaluate resupply or repair needs and store equipment and supplies. As part of this overall termination procedure, much can be learned by discussing the response (what went well, what can be improved) and identifying actions that are needed. For example, there may be a need to revise an SOP or a need for additional monitoring tools. Based on the Simulation just completed, a full Termination will be conducted.

### **Objectives**

---

When you have completed this exercise, you will be better able to:

- Inspect equipment used in the simulation and tag as appropriate
- Properly dispose of contaminated or damaged materials
- Demonstrate use of proper procedures in termination
- Demonstrate an ability to contribute to a critique of a response

## **Termination Activities**

---

A structured termination includes:

- Gathering release data
- Documenting response activities
- Making needed reports to the parent company and/or governmental agencies
- Holding incident critique meetings and making reports
- Evaluating the procedures used and the ERP
- Modifying the ERP
- Checking equipment for damage or contamination
- Documenting disposal
- Performing final decontamination and storing equipment
- Restocking PPE and other response equipment
- Reviewing potential human exposures and following up medically when appropriate

Use of forms included in the ERP to document findings and actions will help ensure that all termination requirements are met and completed.

## **Exercise – Clean up and Critique**

---

This exercise is an opportunity to practice termination—a required skill of emergency responders trained at the Technician level. Use your responses on the Simulation Checklists during the critique. (See Exercise Manual)

## **Summary**

---

Termination activities bring together the information gained during the response, critique of the response and examination of evaluation tools and equipment so that appropriate follow-up can be done such as to:

- Reduce potential for a similar release
- Document need for additional training or other changes to the ERP
- Assure adequate and timely resupply

Appropriate termination procedures and follow-up enhance the capability to respond in the future, should it be necessary.

## **CLOSING AND PROGRAM EVALUATION**

---

Thank you for participating in this program.

This is an opportunity to ask any questions you may have, or to discuss how the knowledge and skills learned can be used at work. Were all your initial questions answered?

Please take the next 10 minutes to complete the program evaluation forms. These are important for improving the program. The Midwest Consortium does take your comments seriously and has made changes in content and the skill exercises based on feedback. Your comments are anonymous.

We hope to see you at another Midwest Consortium program in the future.